

# UM-5

## Miniature Leaded Crystal

- Wide frequency range
- Tight specifications available
- Express manufacturing service
- Fundamental mode up to 55.0MHz

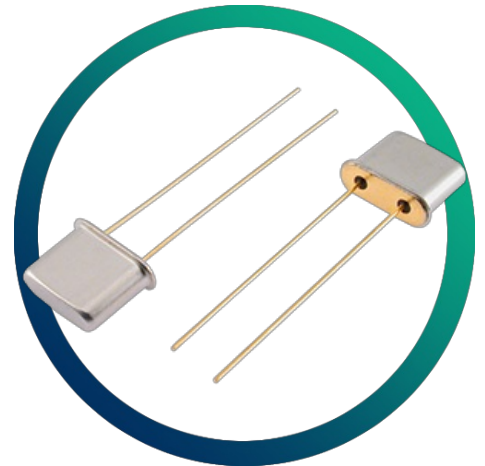

## CONFIGURABLE OPTIONS

| Parameter                          | Option Code |
|------------------------------------|-------------|
| <b>Frequency</b>                   |             |
| <b>Calibration tolerance</b>       |             |
| Any                                |             |
| ±5ppm                              | L           |
| ±7.5ppm                            | M           |
| ±10ppm                             | 1           |
| ±20ppm                             | 2           |
| ±30ppm                             | 3           |
| <b>Temperature stability</b>       |             |
| Any                                |             |
| ±5ppm                              | L           |
| ±7.5ppm                            | M           |
| ±10ppm                             | 1           |
| ±20ppm                             | 2           |
| ±30ppm                             | 3           |
| <b>Operating temperature range</b> |             |
| Any                                |             |
| 0 to +50°C                         | 0           |
| -10 to +60°C                       | 1           |
| -20 to +70°C                       | 2           |
| -30 to +80°C                       | 3           |
| -40 to +85°C                       | 4           |
| <b>Circuit condition</b>           |             |
| Any                                |             |
| 12pF                               | B           |
| 16pF                               | D           |
| 20pF                               | F           |
| 30pF                               | J           |
| Series resonant                    | S           |
| <b>Oscillation mode</b>            |             |
| Any                                |             |
| Fundamental                        | F           |
| 3rd overtone                       | 3           |
| 5th overtone                       | 5           |
| 7th overtone                       | 7           |

**SPECIFICATIONS**

|                                      |                                   |
|--------------------------------------|-----------------------------------|
| Frequency range                      | 10.0 ~ 300MHz                     |
| Dimensions                           | 7.8 x 3.2 x 6.0mm                 |
| Package                              | Resistance weld                   |
| Storage temperature range            | -40 to +85°C                      |
| Static capacitance (C <sub>0</sub> ) | 7pF max                           |
| Equivalent series resistance         | 60Ω max (10.0 ~ 15.99MHz)         |
|                                      | 40Ω max (16.0 ~ 54.99MHz)         |
|                                      | 50Ω max (30.0 ~ 49.99MHz, 3rd OT) |
|                                      | 60Ω max (50.0 ~ 100MHz, 3rd OT)   |
|                                      | 120Ω max (60.0 ~ 150MHz, 5th OT)  |
| 150Ω max (130 ~ 300MHz, 7th OT)      |                                   |
| Ageing                               | ±3ppm max first year              |
| Test drive level                     | 100μW                             |

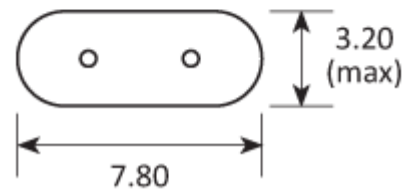
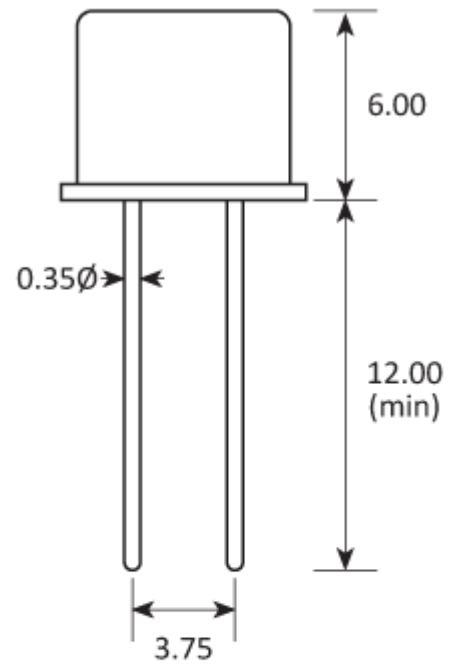
**PACKAGE DRAWING**

Dimensions in mm

## ORDERING INFORMATION

To request a quotation for the UM-5 please use the configurable options form to choose the options you require and then submit your configured product to our team. Our expert advisers are always happy to help with your requirements and can be contacted on +44 1460 256 100 or at [sales@golledge.com](mailto:sales@golledge.com).

Following product selection you will be issued with a seven character Golledge part number. Your Golledge part number is the internationally accepted Golledge manufacturing part number (MPN) that should be used for all project documentation, including bills of materials (BoMs) and purchase orders.

If you have any queries regarding any of our documentation our dedicated sales team will be happy to help.

## HANDLING & STORAGE



Human Body Model (HBM) 1A (250V to <500V)



Moisture Sensitivity Level (MSL): 1 (or not applicable)

## ESR VALUES

The table shows the maximum ESR value in ohms across the frequency range of the UM-5

| Frequency   | Oscillation Mode | ESR Value/ohms |
|-------------|------------------|----------------|
| 10.0 ~ 15.9 | Fundamental      | 60             |
| 16.0 ~ 55.0 | Fundamental      | 40             |
| 30.0 ~ 49.0 | 3rd Overtone     | 50             |
| 50.0 ~ 100  | 3rd Overtone     | 60             |
| 60.0 ~ 150  | 5th Overtone     | 120            |
| 130 ~ 300   | 7th Overtone     | 150            |

## CONSTRUCTION

Resistance weld

## COMPLIANCE

---

Please refer to our **DOCUMENTS** section for more information.

 Lead-free (< 0.1% by weight )

 RoHS compliant with no exemptions.

 REACH compliant.

 Free of conflict minerals.

 Free from halogens.

 Free from ozone-depleting substances.