

1030.0MHz SAW Filter
Part No: MP11168

Model: TA2002A
Rev No: 1

A. MAXIMUM RATING:

Electrostatic Sensitive Device (ESD)

1. Input Power Level: 20dBm
2. DC Voltage: 3V
3. Operating Temperature: -40°C to +85°C
4. Storage Temperature: -40°C to +85°C

B. ELECTRICAL CHARACTERISTICS:

1. Terminating source impedance (single): $Z_S = 50\Omega$
2. Terminating load impedance (single): $Z_L = 50\Omega$

Item	Unit	Min.	Typ.	Max
Center frequency F_c	MHz	-	1030	-
Insertion Loss (1027 ~ 1033MHz) IL	dB	-	2.7	4.0
Amplitude ripple (1027 ~ 1033MHz)	dB	-	1.0	2.2
Group delay (1027~1033MHz)	ns	40	50	60
Variation of group delay (1027~1033MHz)	ns		10	20 ¹⁾
VSWR (1027 ~ 1033MHz)	-	-	1.6	2.4
Attenuation (Reference level from 0dB)				
DC ~ 910MHz	dB	45	50	-
1046MHz	dB	5	34	-
1090 ~ 1300MHz	dB	45	50	-
Temperature coefficient of frequency	ppm/°C	-	-36	-

Averaged over 2MHz

C. TEST CIRCUIT:

HP Network analyzer

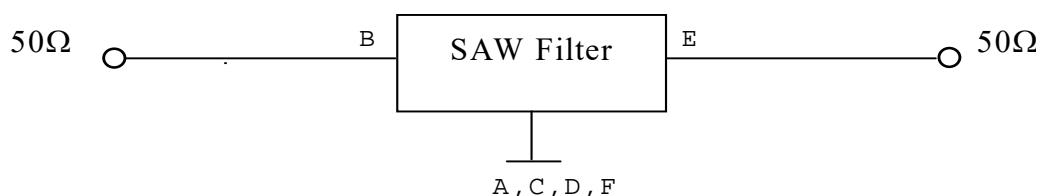

1030.0MHz SAW Filter
Part No: MP11168

Model: TA2002A
Rev No: 1

D. FREQUENCY CHARACTERISTICS:

1. S21 response: Center 1030MHz, Span 200MHz

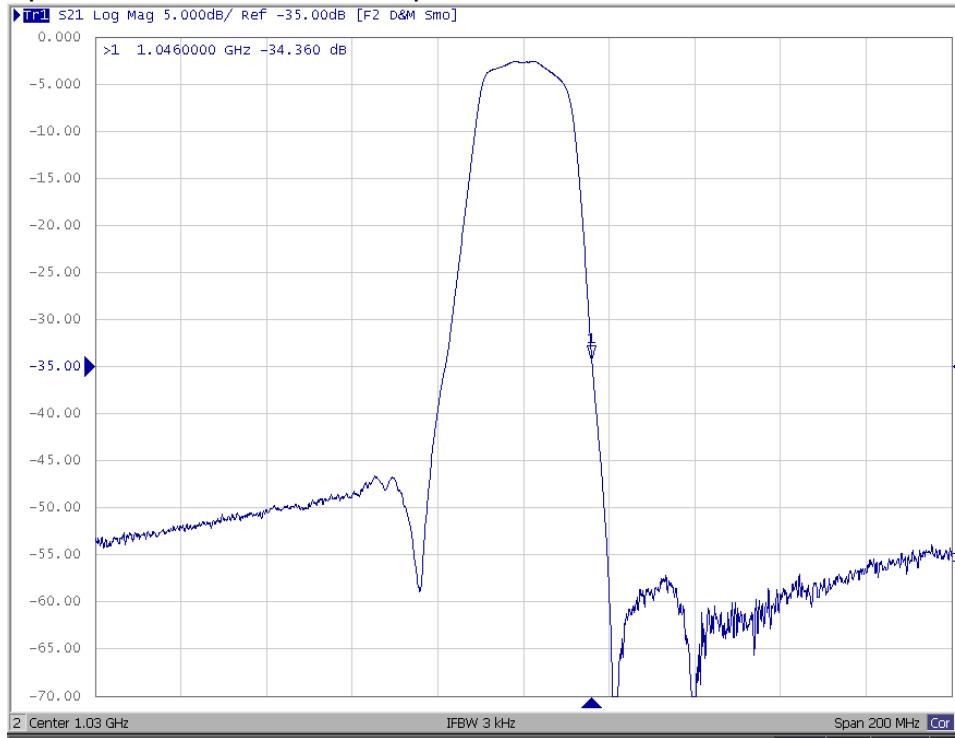

2. S21 respons: Span 50MHz

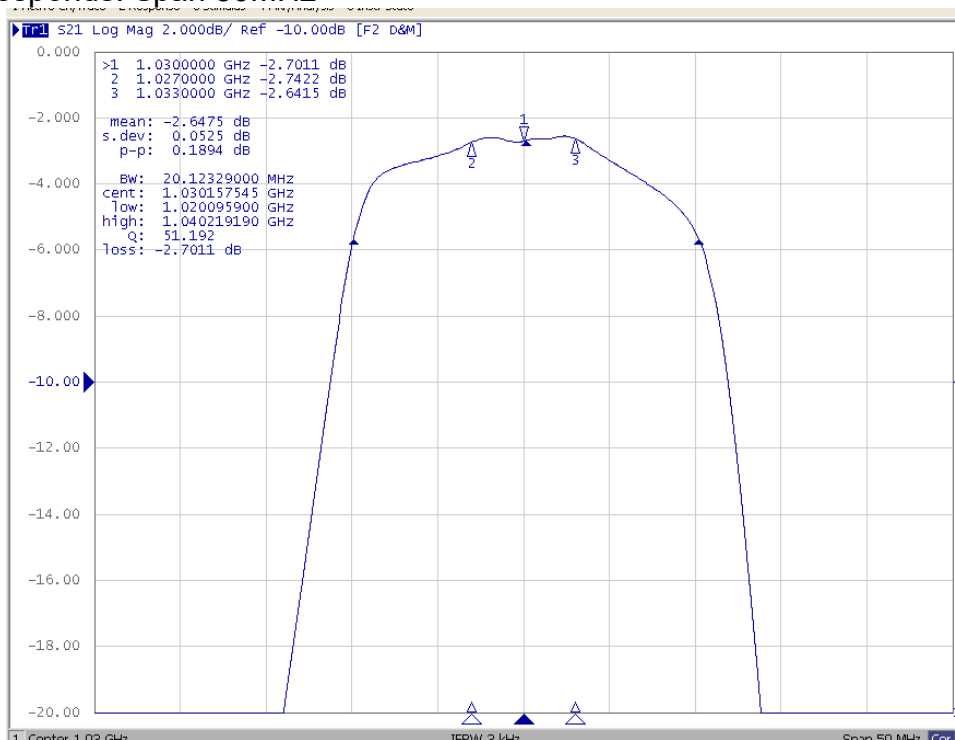

1030.0MHz SAW Filter
Part No: MP11168

Model: TA2002A
Rev No: 1

3. S21 response: 1MHz ~ 2000MHz

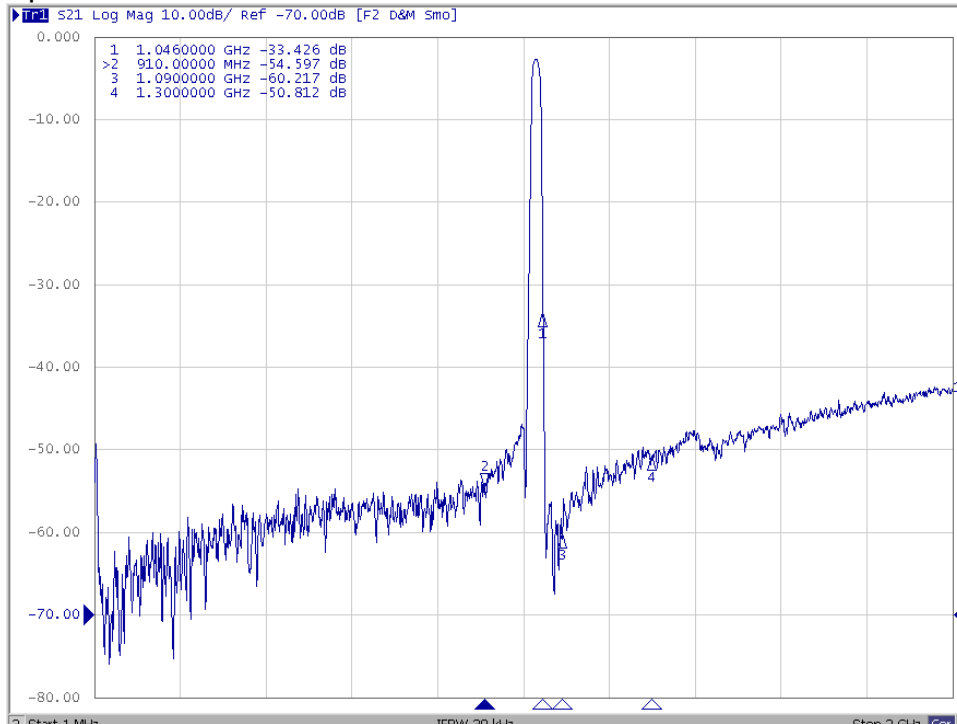

Reflection Functions

1. S11 VSWR: Center 1030MHz, Span 50MHz

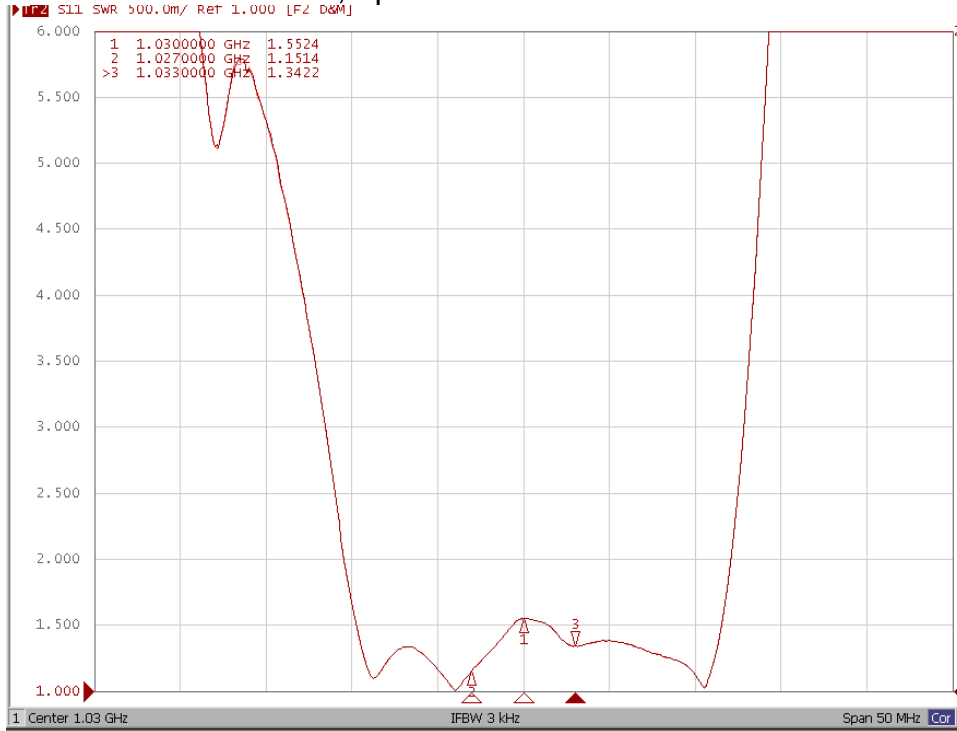

1030.0MHz SAW Filter
Part No: MP11168

Model: TA2002A
Rev No: 1

2. S11 VSWR: Center 1030MHz, Span 50MHz

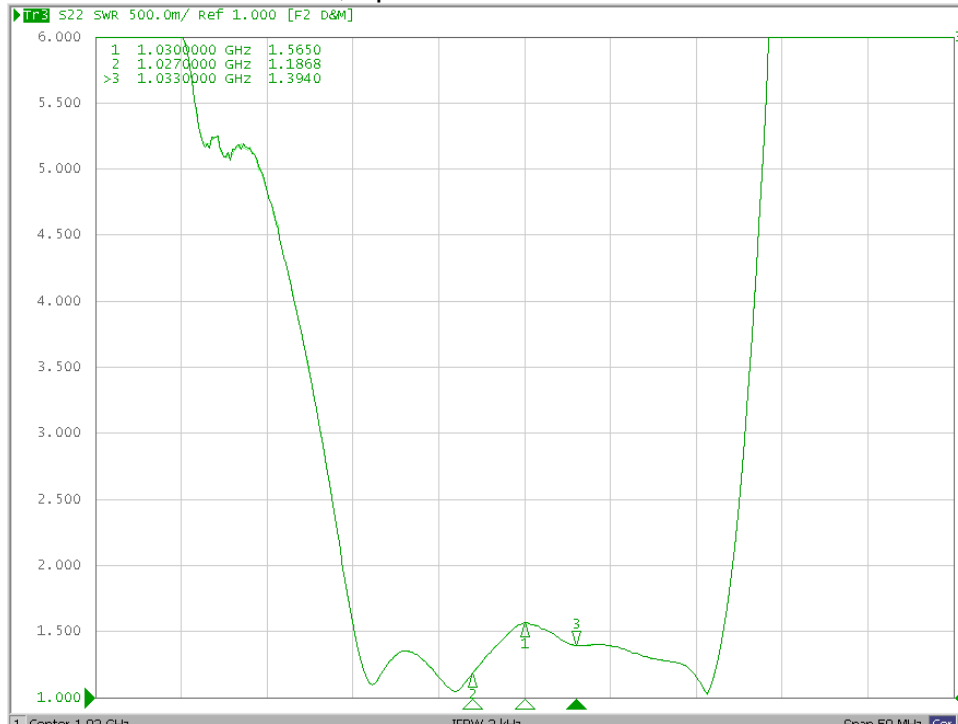

3. G_Delay response :(Span 20MHz)

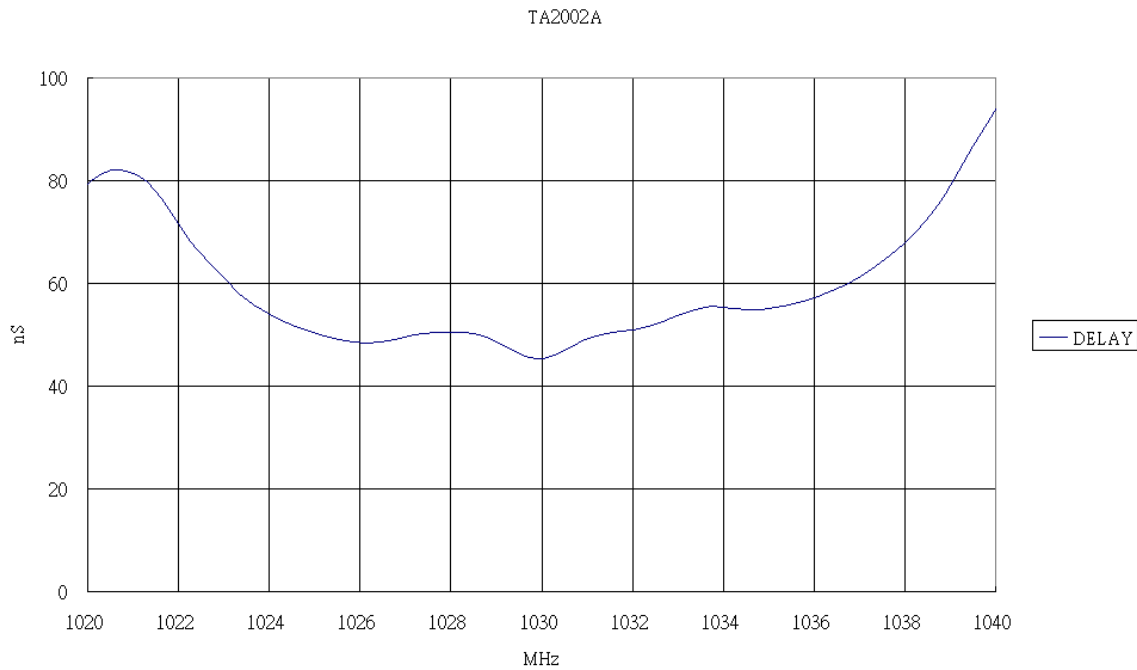

1030.0MHz SAW Filter
Part No: MP11168

Model: TA2002A
Rev No: 1

E. OUTLINE DRAWING:

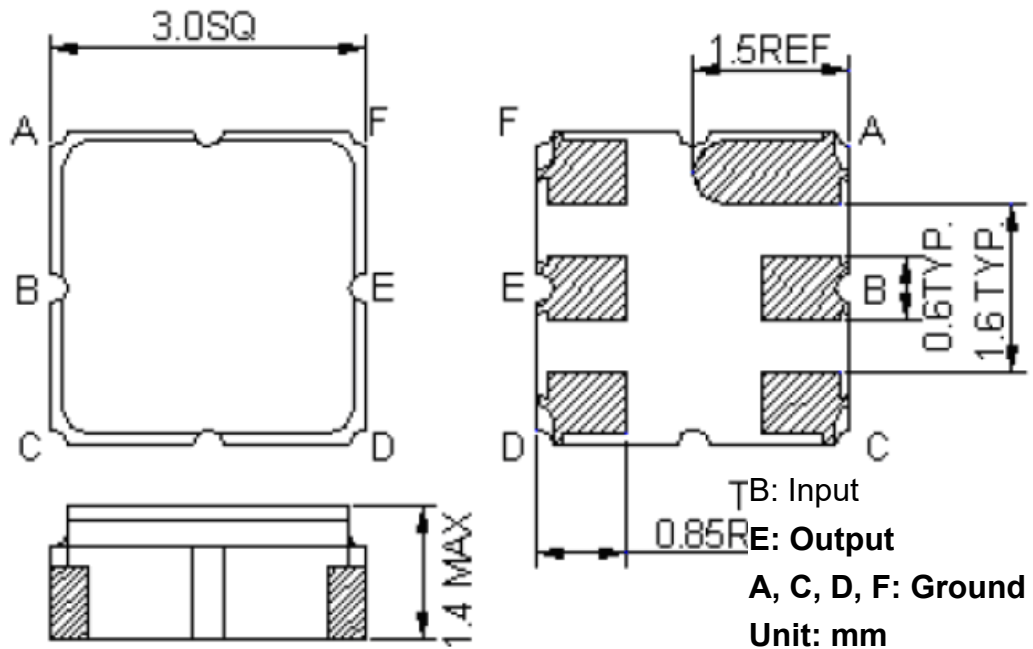

F. PCB FOOTPRINT:

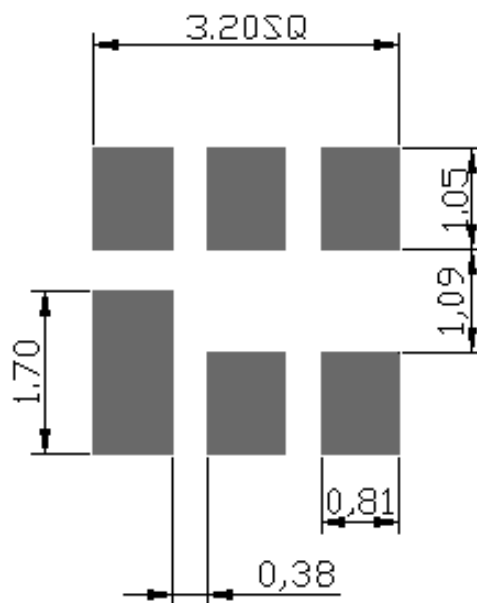

1030.0MHz SAW Filter
Part No: MP11168

Model: TA2002A
Rev No: 1

G. PACKING:

1. Reel Dimensions

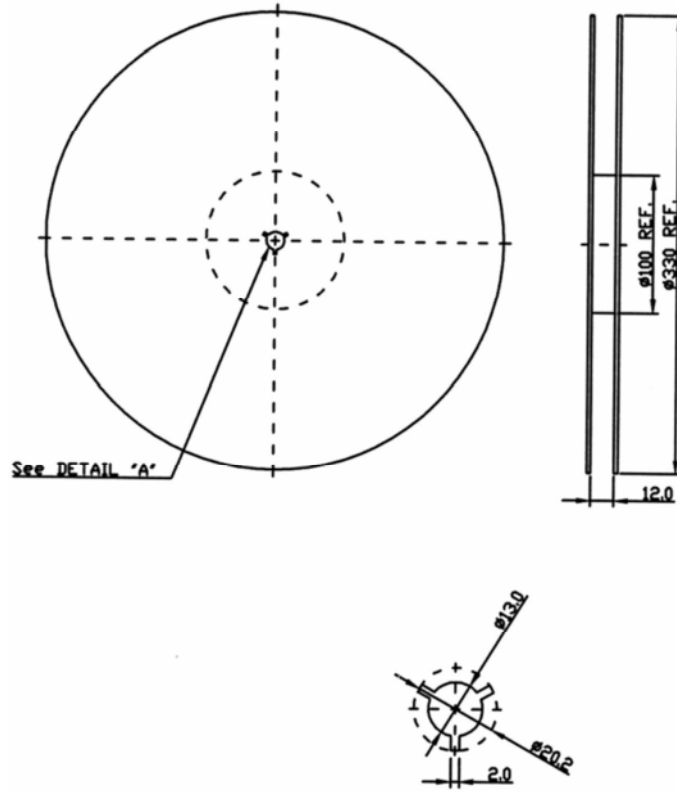

2. Tape Dimensions

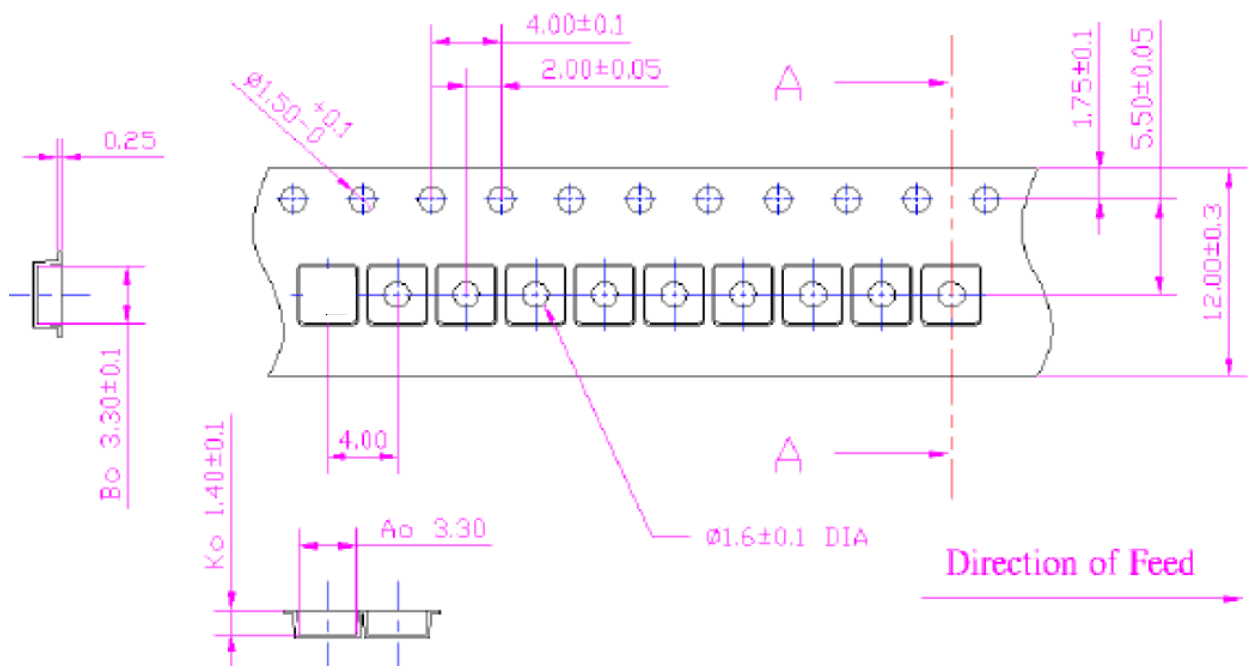

1030.0MHz SAW Filter
Part No: MP11168

Model: TA2002A
Rev No: 1

H. RECOMMENDED REFLOW PROFILE:

1. Preheating shall be fixed at 150~180°C for 60~90 seconds.
2. Ascending time to preheating temperature 150°C shall be 30 seconds min.
3. Heating shall be fixed at 220°C for 50~80 seconds and at 260°C +0/-5°C peak (20~40 sec).
4. Time: 2 times.

