

SAW Filter: 1095.0MHz

Model: TA2176A

Part No: MP10586

Rev No: 1

A. MAXIMUM RATING:

Electrostatic Sensitive Device (ESD)

1. Input Power Level: 10dBm
2. DC voltage: 3V
3. Operating Temperature: -55°C to +85°C
4. Storage Temperature: -55°C to +85°C

B. ELECTRICAL CHARACTERISTICS:

Item	Unit	Min.	Typ.	Max.
Center frequency Fc	MHz	-	1095	-
Insertion Loss (1073 ~ 1117MHz) IL	dB	-	3.8	4.2
Amplitude Ripple (1073 ~ 1117MHz)	dB	-	0.6	1.5
VSWR (1073 ~ 1117MHz)	-	-	1.4	2.4
Attenuation (Reference level from 0dB)				
10 ~ 975MHz	dB	23	29	-
1160 ~ 1200MHz	dB	10	15	-
1260 ~ 1460MHz	dB	25	33	-
Temperature Coefficient of Frequency	ppm/°C	-	-80	-

C. MEASUREMENT CIRCUIT:

HP Network analyzer

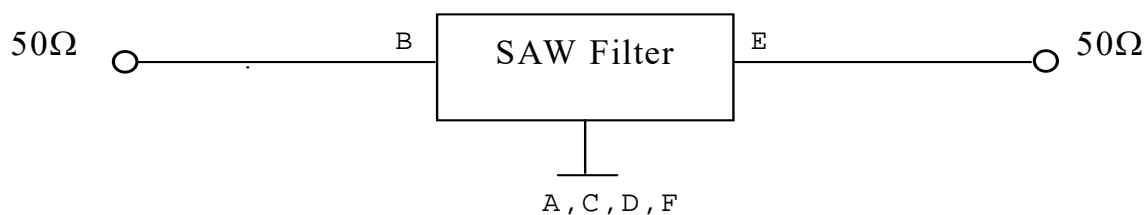

SAW Filter: 1095.0MHz
Part No: MP10586

Model: TA2176A
Rev No: 1

D. OUTLINE DRAWING:

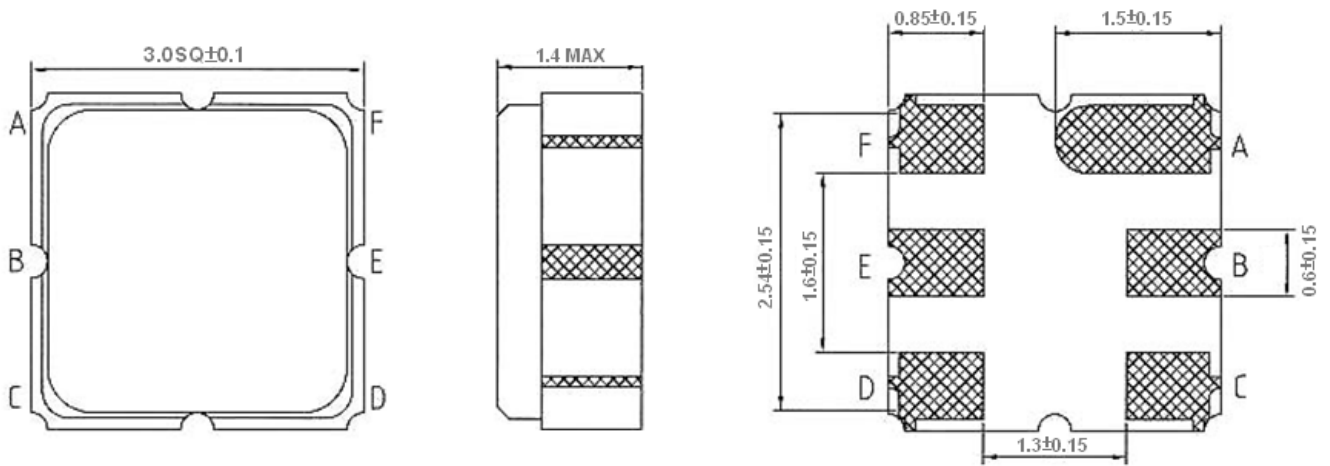

B: Input
 E: Output
 A, C, D, F: Ground
 Unit: mm

E. PCB FOOTPRINT:

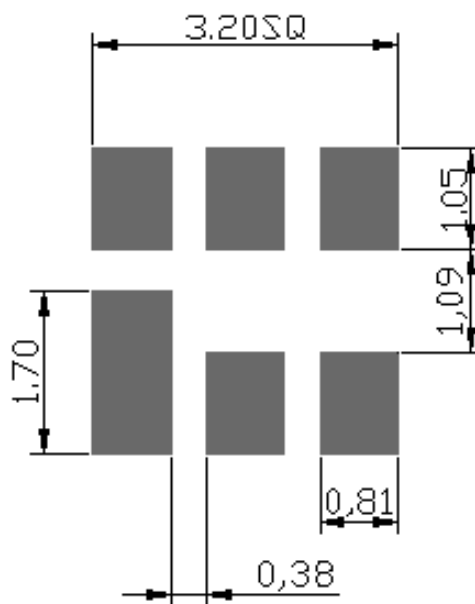

SAW Filter: 1095.0MHz
Part No: MP10586

Model: TA2176A
Rev No: 1

F. FREQUENCY CHARACTERISTICS:

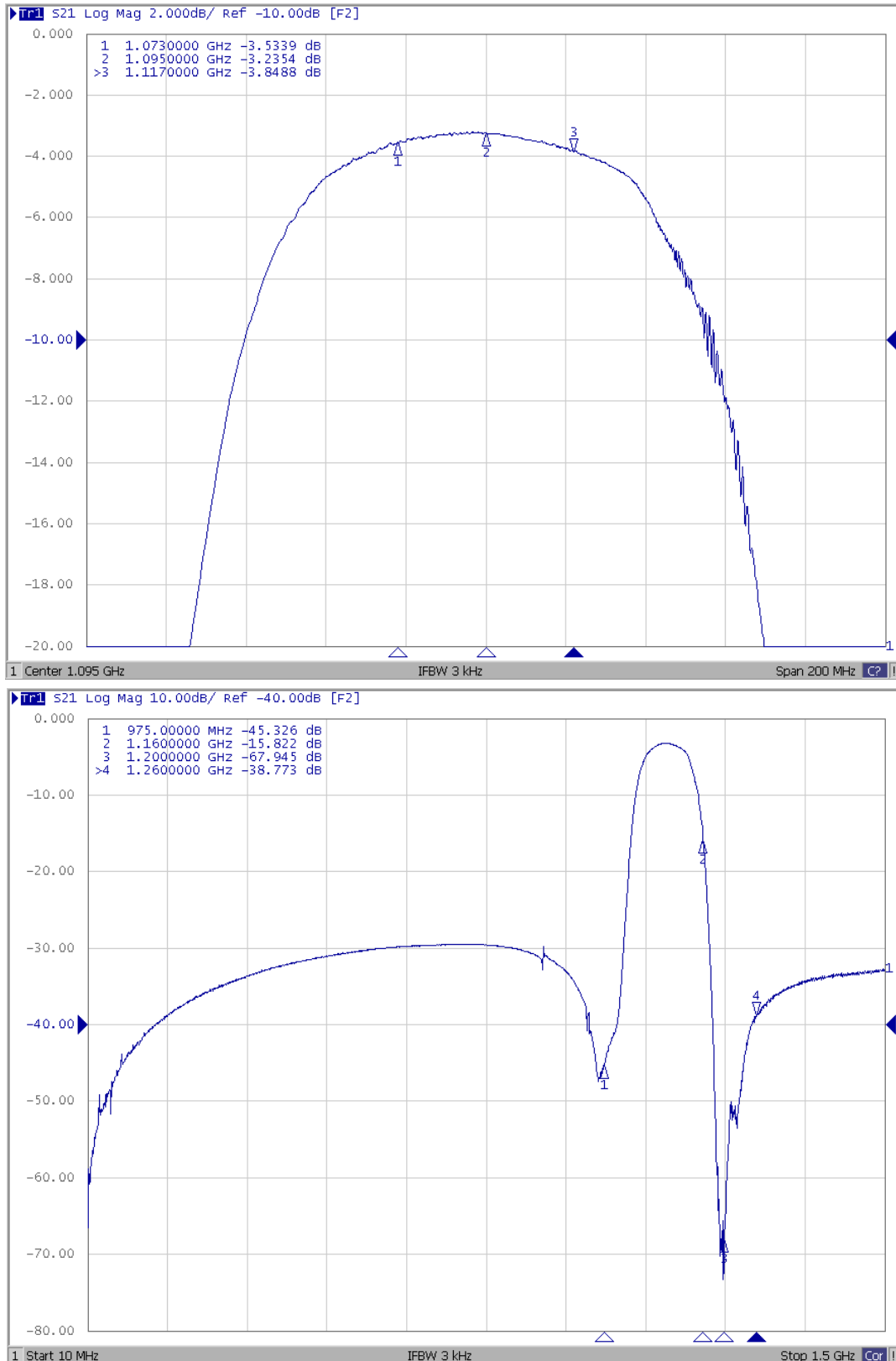

SAW Filter: 1095.0MHz
Part No: MP10586

Model: TA2176A
Rev No: 1

Reflection Functions:

S11

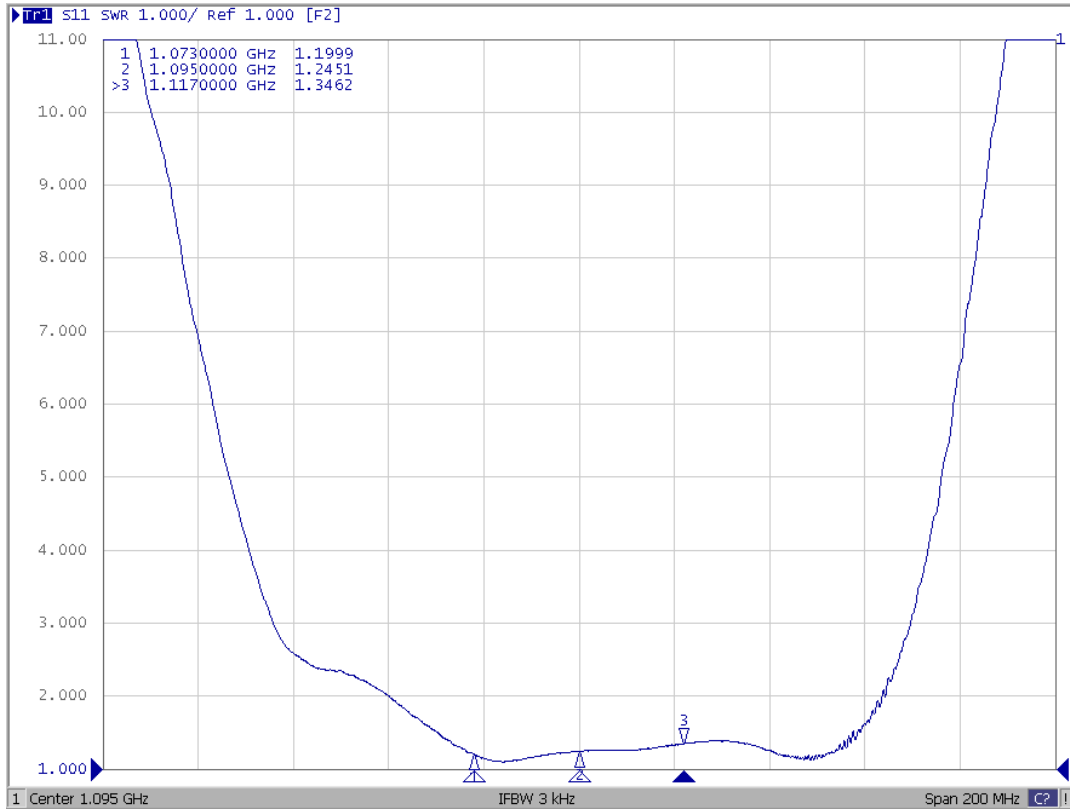

S22

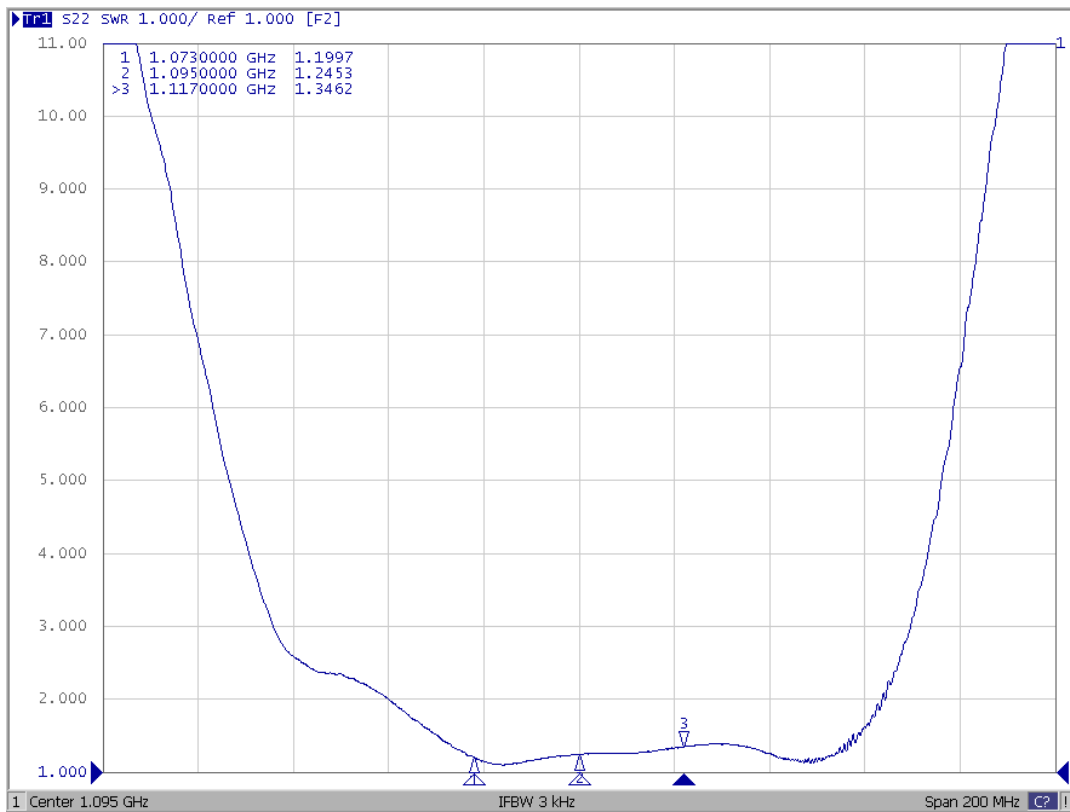

SAW Filter: 1095.0MHz
Part No: MP10586

Model: TA2176A
Rev No: 1

G. PACKING:

1. Reel Dimensions

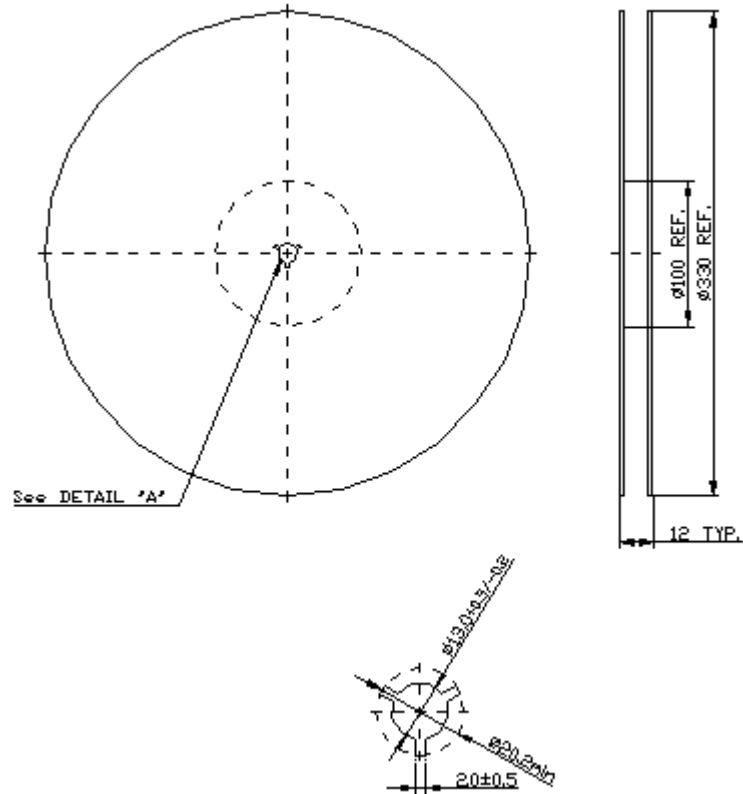

2. Tape Dimensions

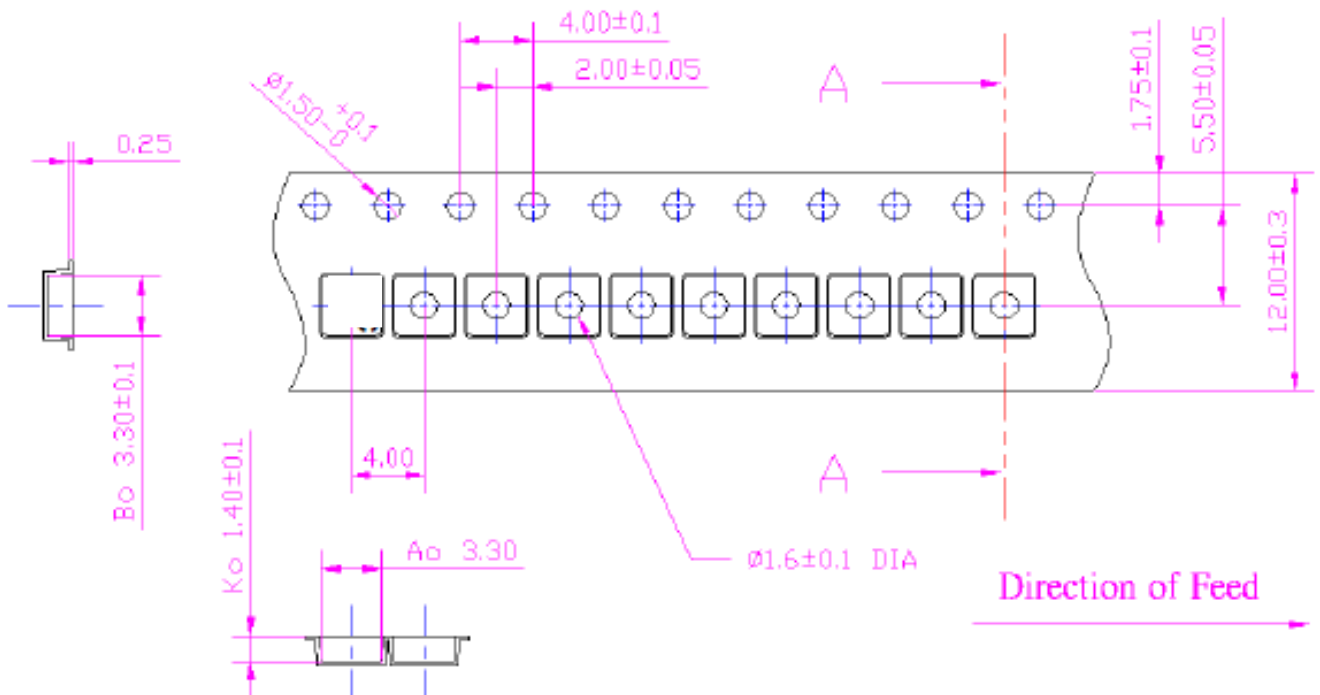

SAW Filter: 1095.0MHz
Part No: MP10586

Model: TA2176A
Rev No: 1

H. RECOMMENDED REFLOW PROFILE:

1. Preheating shall be fixed at 150 ~ 180°C for 60 ~ 90 seconds.
2. Ascending time to preheating temperature 150°C shall be 30 seconds min.
3. Heating shall be fixed at 220°C for 50 ~ 80 seconds and at 260°C +0/-5°C peak (20 ~ 40 sec).
4. Time: 2 times.

