

SAW Filter: 802.0MHz
Part No: MP10413

Model: TA2374A
Rev No: 1

A. MAXIMUM RATING:

Electronic Sensitive Device (ESD)

1. Input Power Level: 10dBm
2. DC voltage: 3V
3. Operating Temperature: -20°C to +85°C
4. Storage Temperature: -55°C to +125°C
5. Moisture Sensitivity Level: Level 1 (MSL1)

B. ELECTRICAL CHARACTERISTICS:

Ambient Temperature: 25°C

Item	Unit	Min.	Typ.	Max.
Center frequency, Fc	MHz	-	802	-
Insertion Loss (794 ~ 810MHz) IL	dB	-	1.65	3.0
Pass band(794 ~ 810MHz)	MHz	16	32	-
Attenuation:(Reference level from 0dB)				
100.00 ~ 722MHz	dB	50	58	-
882.00 ~ 1200MHz	dB	50	55	-
Temperature Coefficient	ppm/°C	-	-36	-
Source Impedance	Ohm	-	50	-
Load Impedance	Ohm	-	50	-

C. MEASUREMENT CIRCUIT:

HP Network analyzer

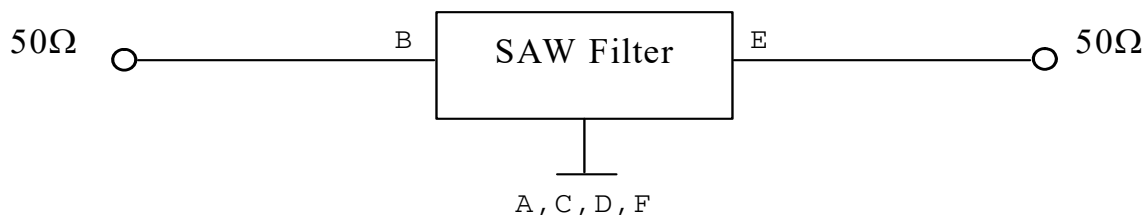

SAW Filter: 802.0MHz
Part No: MP10413

Model: TA2374A
Rev No: 1

D. FREQUENCY CHARACTERISTICS:

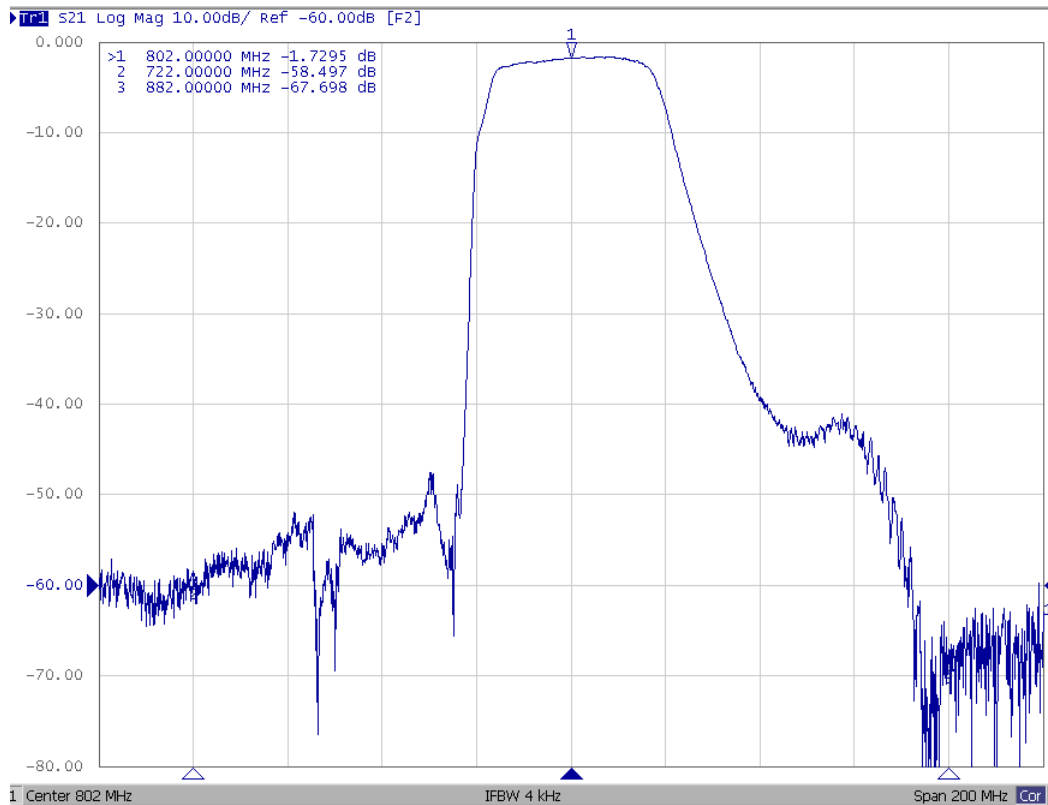
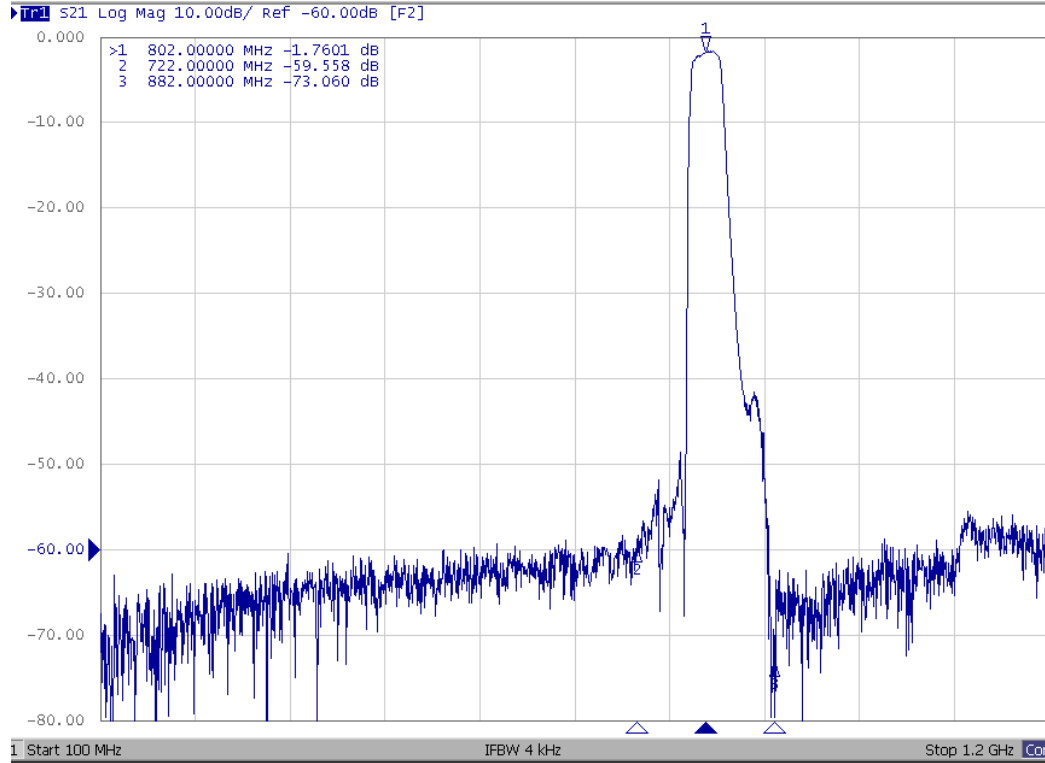

SAW Filter: 802.0MHz
Part No: MP10413

Model: TA2374A
Rev No: 1

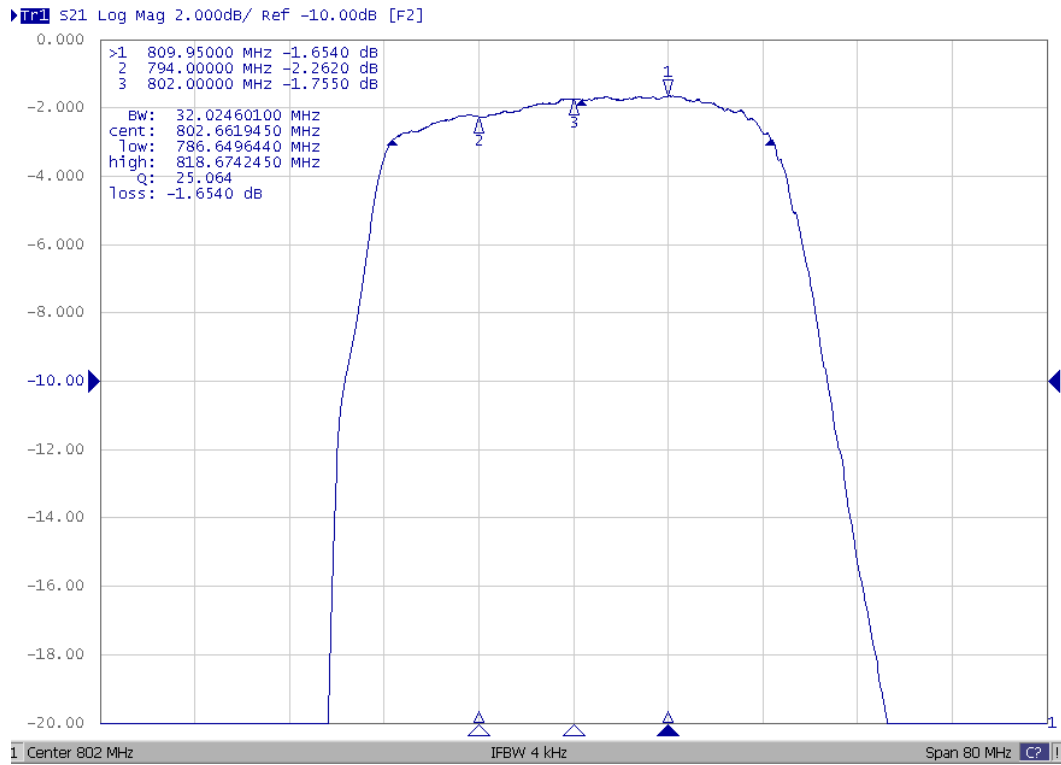

SAW Filter: 802.0MHz
Part No: MP10413

Model: TA2374A
Rev No: 1

E. OUTLINE DRAWING:

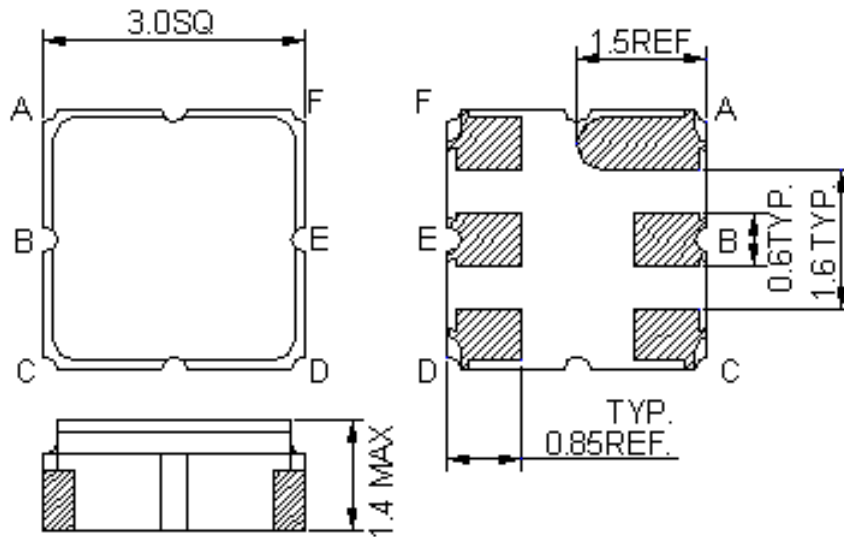

B: Input
E: Output
A, C, D, F: Ground
Unit: mm

SAW Filter: 802.0MHz
Part No: MP10413

Model: TA2374A
Rev No: 1

F. PCB FOOTPRINT:

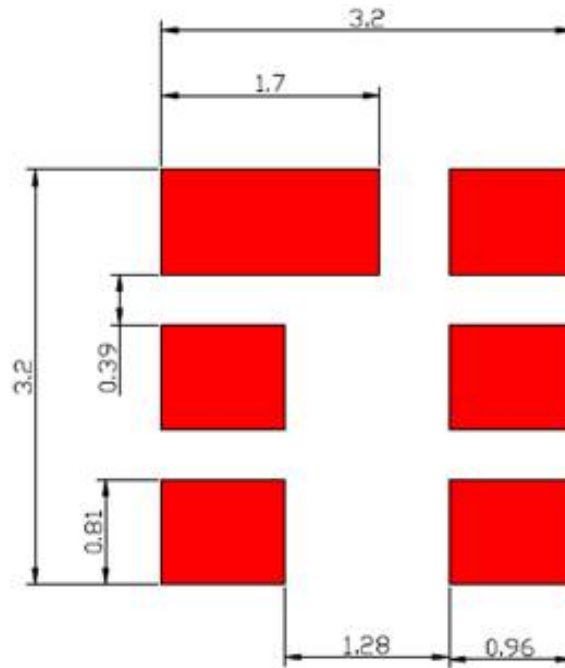

SAW Filter: 802.0MHz

Model: TA2374A

Part No: MP10413

Rev No: 1

G. PACKING:

1. Reel Dimensions

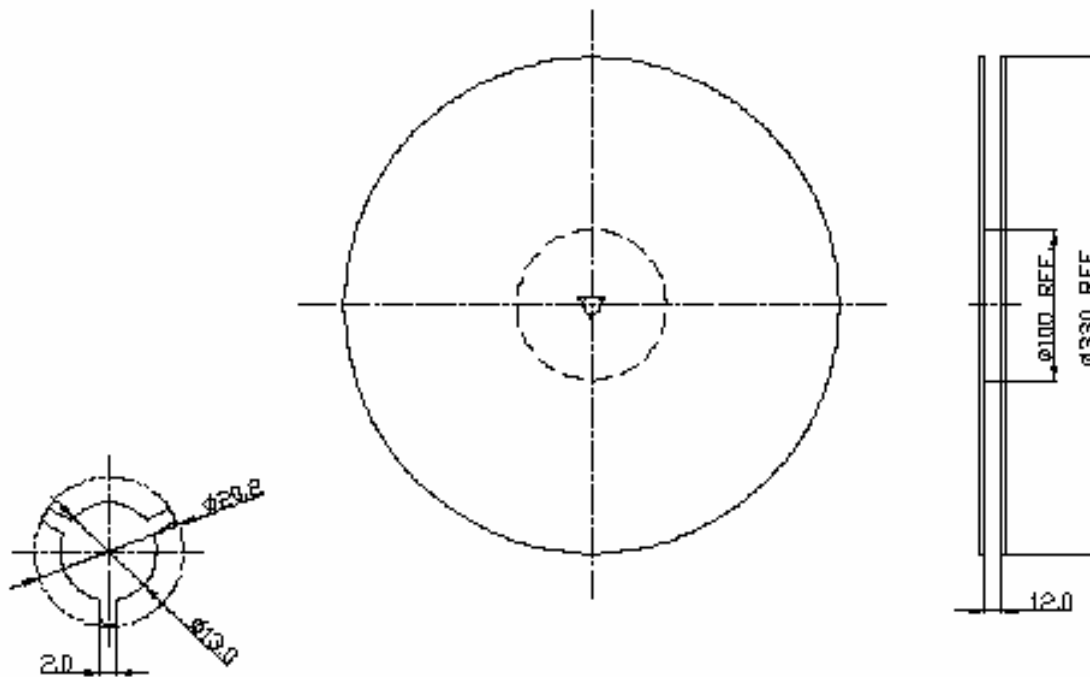

2. Tape Dimensions

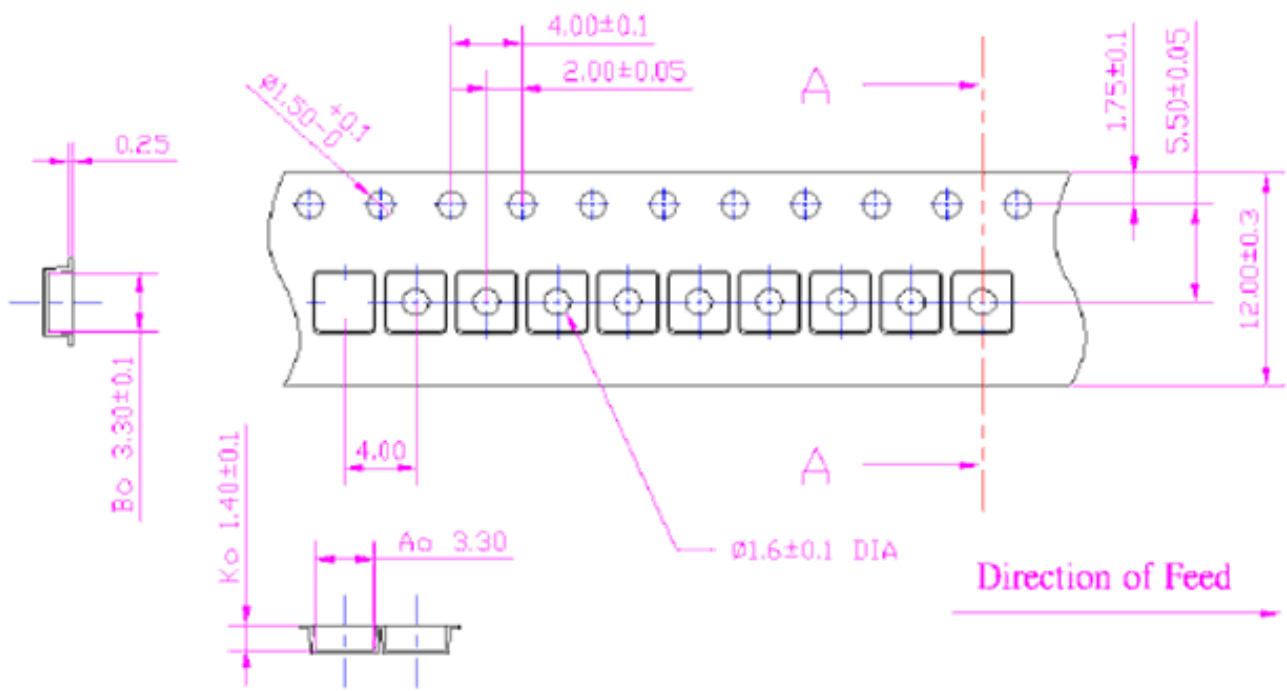

SAW Filter: 802.0MHz
Part No: MP10413

Model: TA2374A
Rev No: 1

H. RECOMMENDED REFLOW PROFILE:

1. Preheating shall be fixed at 150 ~ 180°C for 60 ~ 90 seconds.
2. Ascending time to preheating temperature 150°C shall be 30 seconds min.
3. Heating shall be fixed at 220°C for 50 ~ 80 seconds and at 260°C +0/-5°C peak (20 ~ 40 sec).
4. Time: 2 times.

