

**SAW Filter 847.0MHz**  
**Part No: MP07856**

**Model: TA2042A**  
**Rev No: 2**

**A. MAXIMUM RATING:**

Electrostatic Sensitive Device (ESD)

1. Operating temperature range: -30°C to +85°C
2. Storage temperature range: -40°C to +100°C
3. Input power: 10dBm
4. Maximum DC Voltage: ±5V
5. Moisture Sensitivity Level: Level 1 (MSL1)
6. ESD 100V (MM), 200V (HBM)

**B. ELECTRICAL CHARACTERISTICS:**

1. Terminating source impedance:  $Z_S = 50\Omega$
2. Terminating load impedance:  $Z_L = 50\Omega$

Parameters Description		Unit	Min	Typ.	Max	Remarks
Insertion Loss	832 ~ 862MHz	dB(*1)	-	2.0	2.5	
Amplitude ripple	832 ~ 862MHz	dB	-	0.9	1.6	
VSWR	Input	832 ~ 862MHz	-	-	2.3	2.5
	Output	832 ~ 862MHz	-	-	2.3	2.5
Attenuation:						
DC ~ 791MHz		dB	30	55	-	
791 ~ 821MHz		dB	40	48	-	
925 ~ 960MHz		dB	20	50	-	
1565.42 ~ 1573.374MHz		dB	35	47	-	
1573.374 ~ 1577.466MHz		dB	35	47	-	
1577.466 ~ 1585.42MHz		dB	35	46	-	
1597.5515 ~ 1605.886MHz		dB	35	46	-	
1664 ~ 1724MHz		dB	25	45	-	
1805 ~ 1880MHz		dB	25	44	-	
2110 ~ 2170MHz		dB	25	42	-	
2400 ~ 2500MHz		dB	30	41	-	
2496 ~ 2586MHz		dB	30	40	-	
2570 ~ 2620MHz		dB	30	40	-	
2620 ~ 2690MHz		dB	25	39	-	
3328 ~ 3448MHz		dB	20	37	-	
Input impedance		$\Omega$	50			single-ended
Output impedance		$\Omega$	50			single-ended

Note: Specification of insertion loss includes loss that comes from the test board (0.05dB).

**SAW Filter 847.0MHz**  
**Part No: MP07856**

**Model: TA2042A**  
**Rev No: 2**

**C. FREQUENCY CHARACTERISTICS:**

1. Passband:

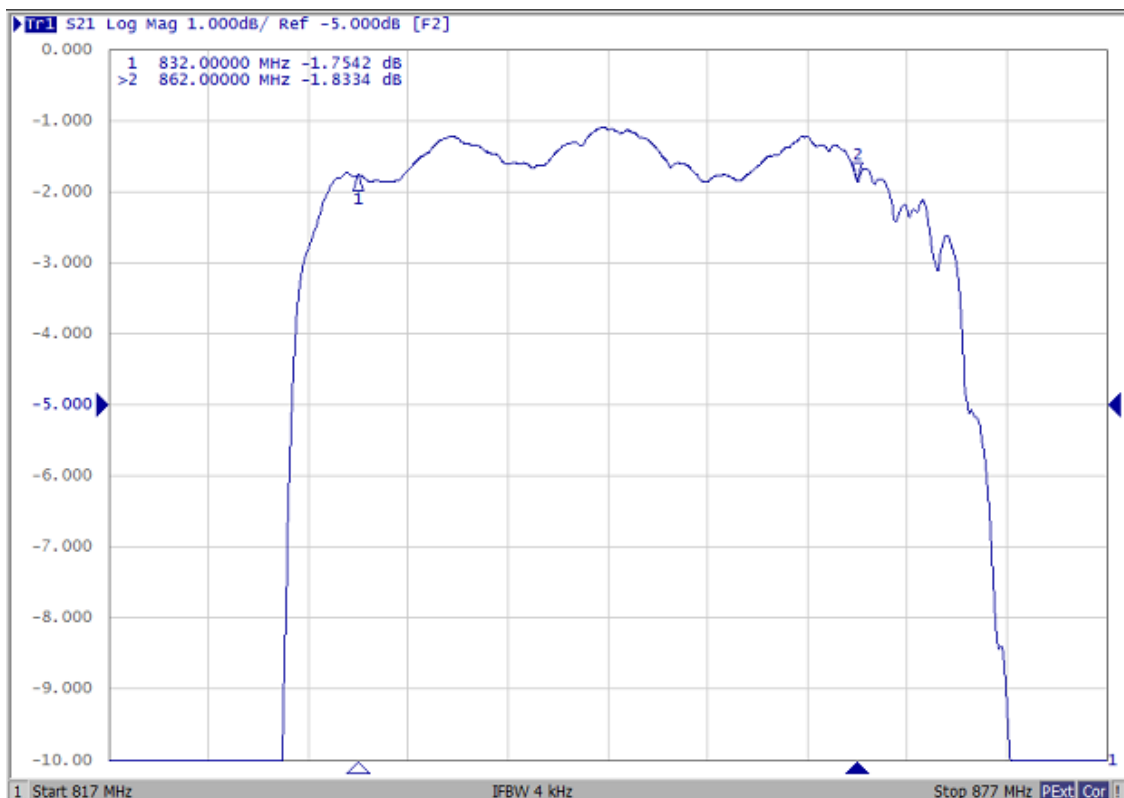
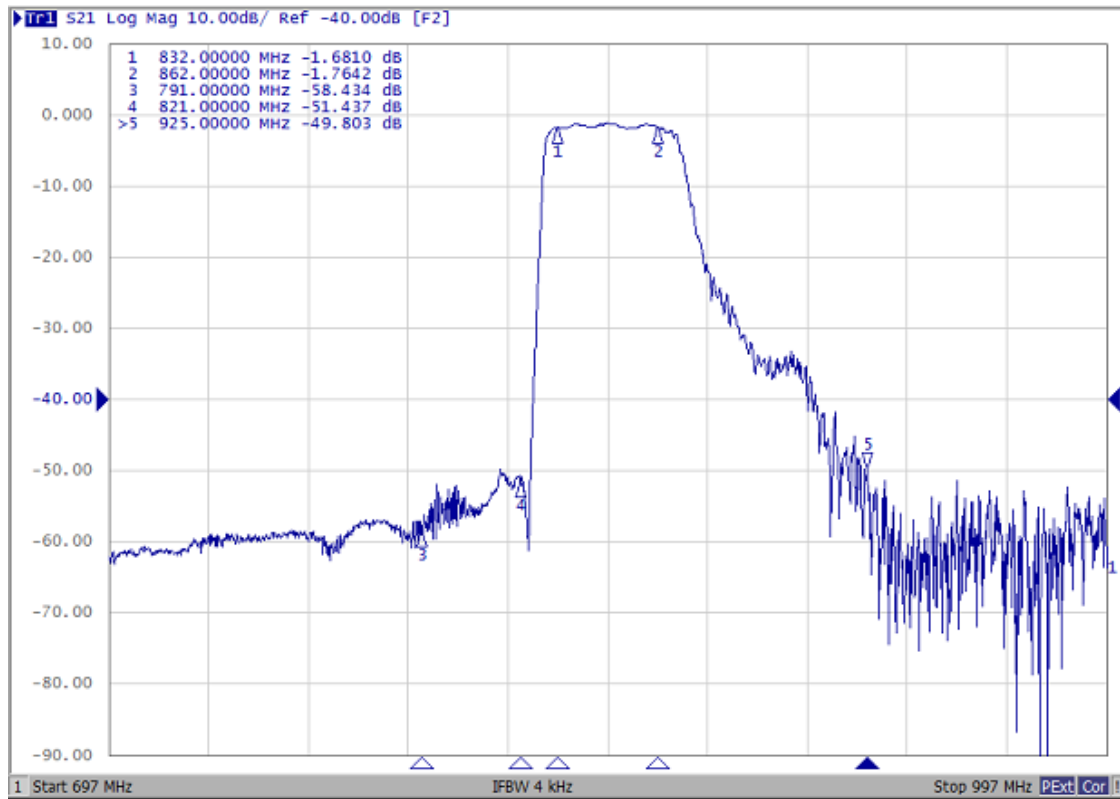

**SAW Filter 847.0MHz**  
**Part No: MP07856**

**Model: TA2042A**  
**Rev No: 2**

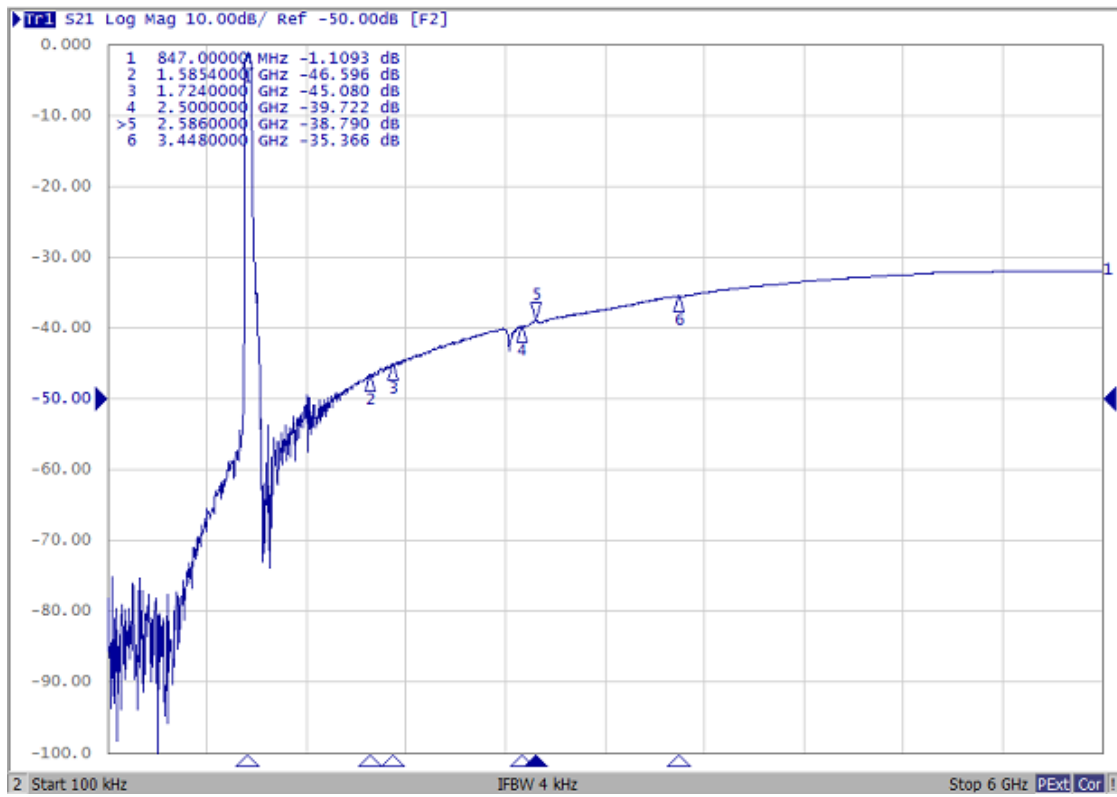

**SAW Filter 847.0MHz**  
**Part No: MP07856**

**Model: TA2042A**  
**Rev No: 2**

2. Reflection Functions:

S11 VSWR

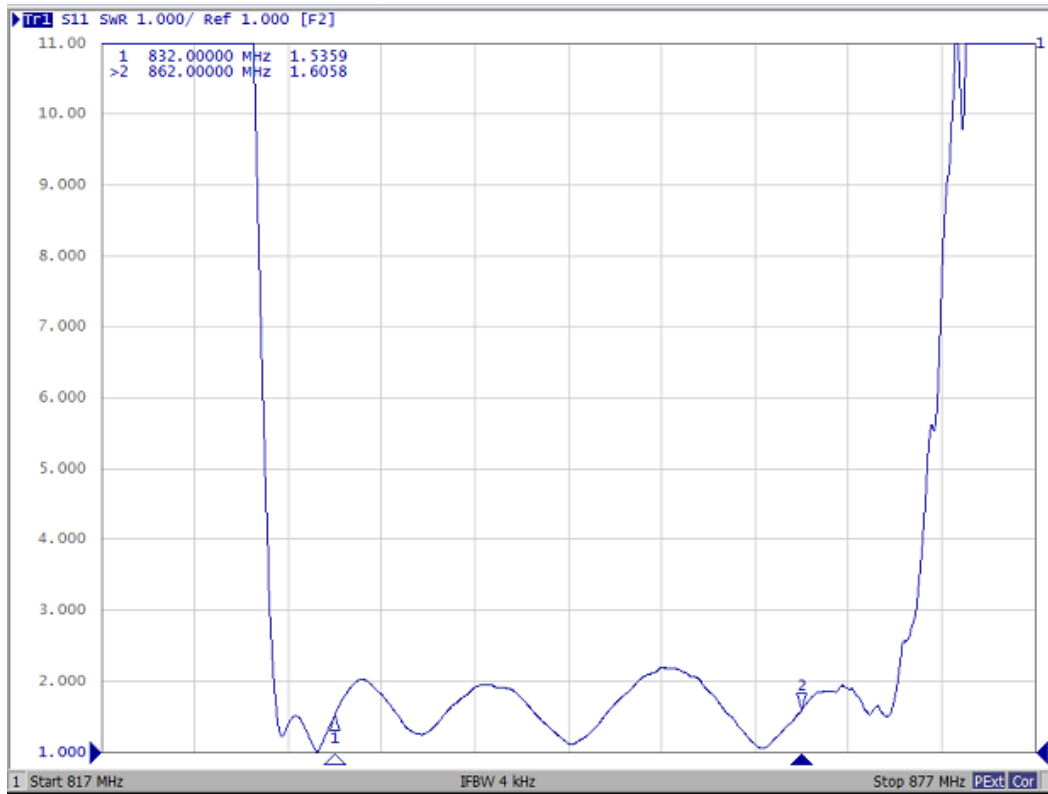

S22 VSWR

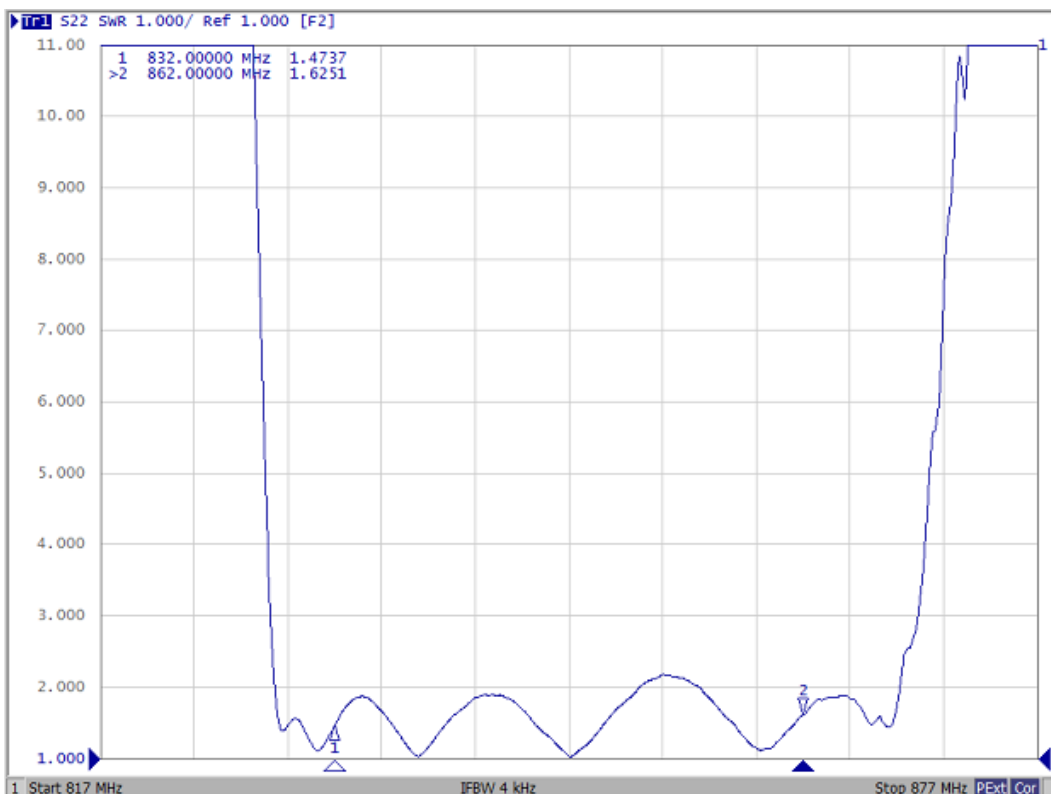

**SAW Filter 847.0MHz**  
**Part No: MP07856**

**Model: TA2042A**  
**Rev No: 2**

S11 Smith Chart

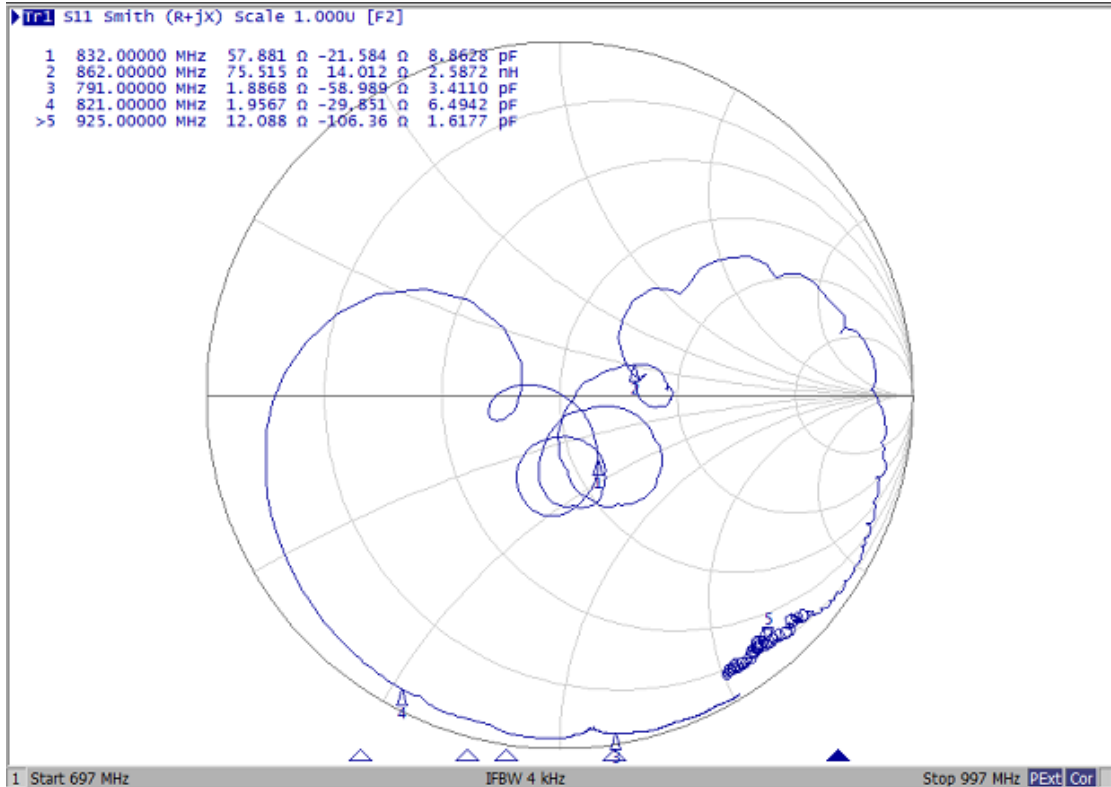

S22 Smith Chart

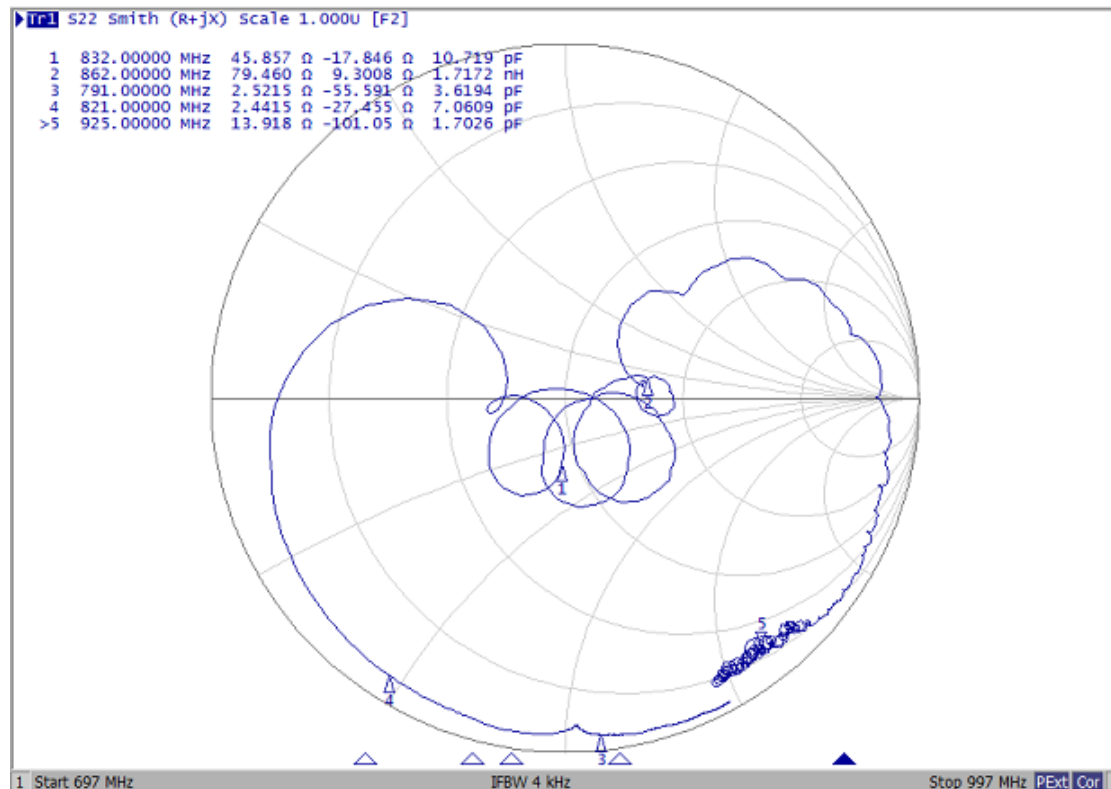

**SAW Filter 847.0MHz**  
**Part No: MP07856**

**Model: TA2042A**  
**Rev No: 2**

**D. OUTLINE DRAWING:**

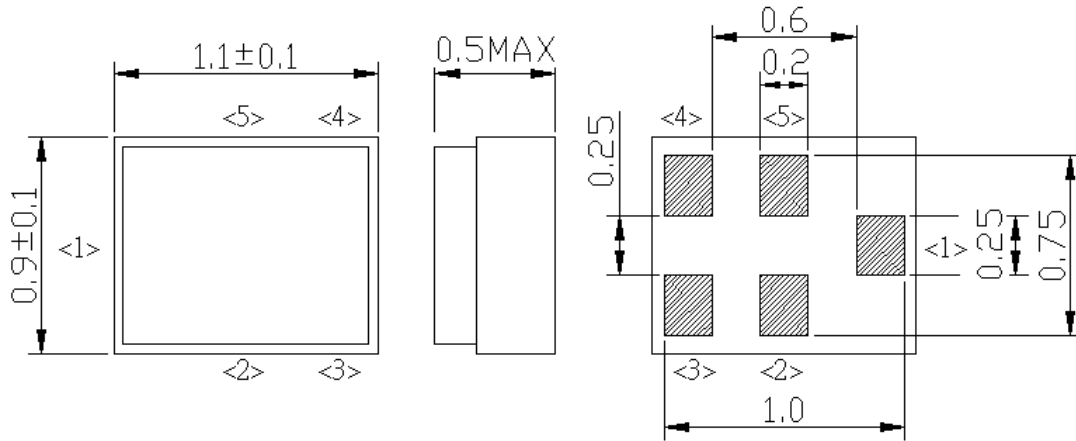

**Pin Configuration**

Pin No.	Symbol	Function
1	IN	Single-ended pin
2	GND	Ground
3	GND	Ground
4	OUT	Single-ended pin
5	GND	Ground

**E. EVALUATION CIRCUIT:**

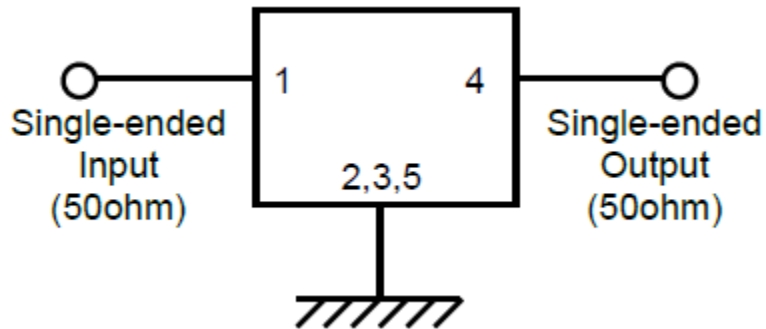

**F. PCB FOOTPRINT:**

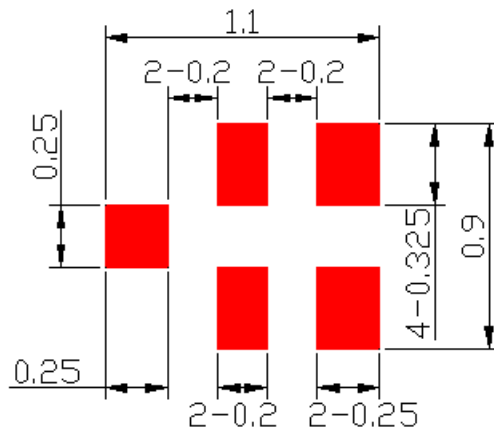

: Land Pattern  
 Unit: mm

**SAW Filter 847.0MHz**  
**Part No: MP07856**

**Model: TA2042A**  
**Rev No: 2**

**G. PACKING:**

1. Reel Dimension

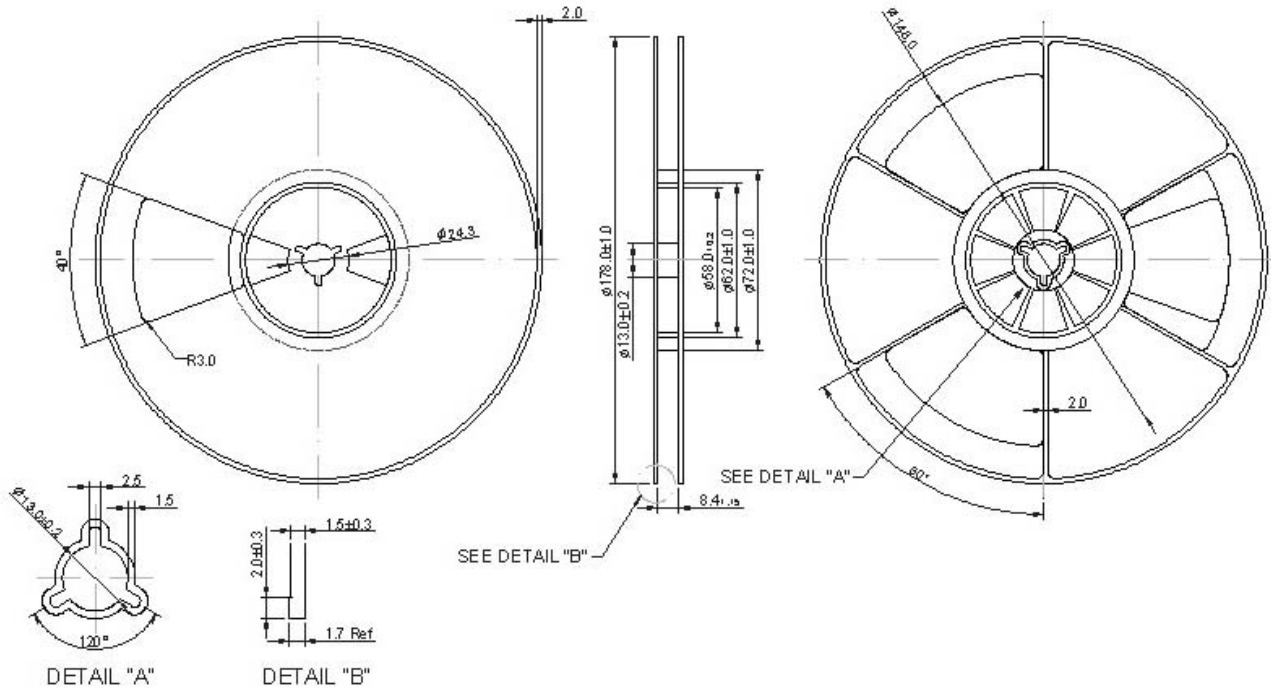

2. Tape Dimension

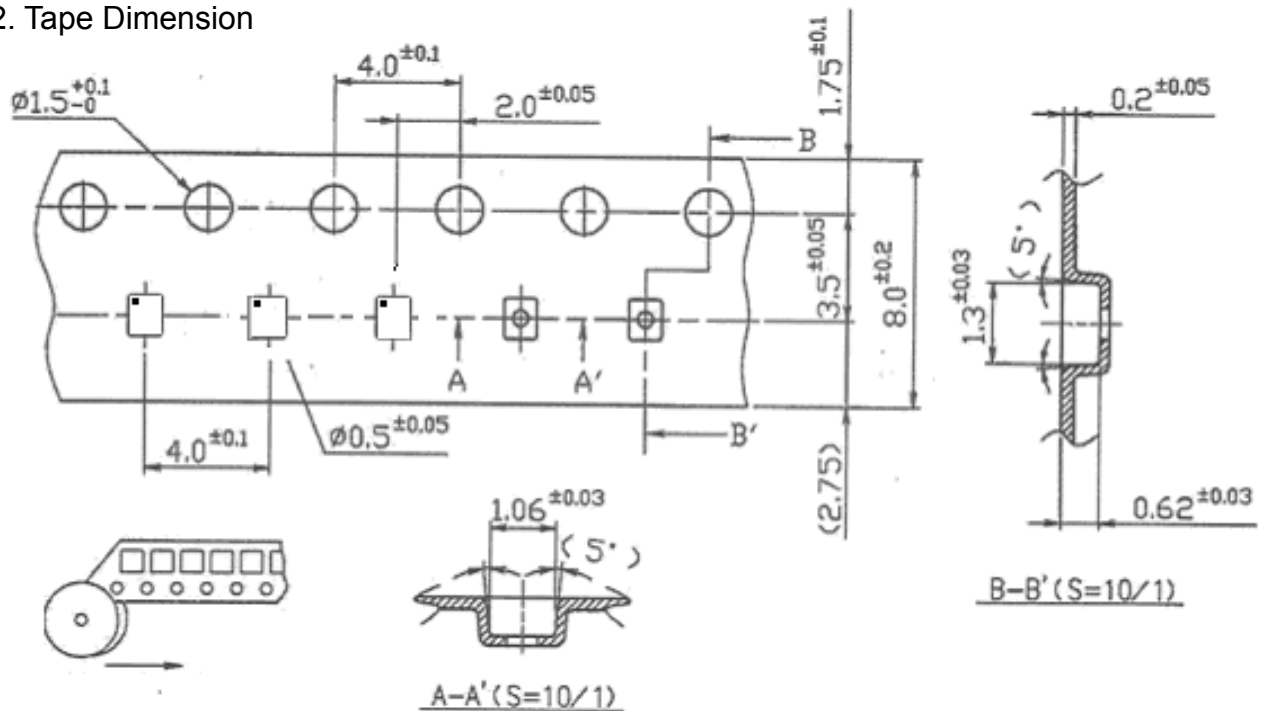

**SAW Filter 847.0MHz**  
**Part No: MP07856**

**Model: TA2042A**  
**Rev No: 2**

**H: RECOMMENDED REFLOW PROFILE:**

1. Preheating shall be fixed at 150 ~ 180°C for 60 ~ 90 seconds.
2. Ascending time to preheating temperature 150°C shall be 30 seconds min.
3. Heating shall be fixed at 220°C for 50 ~ 80 seconds and at 245 ~ 260°C peak (min. 10 sec).
4. Time: 2 times.

