

SAW Filter 881.50MHz
Part No: MP07842

Model: TA1811A
Rev No: 1

A. MAXIMUM RATING:

Electrostatic Sensitive Device (ESD)

1. Maximum Input Power: 10 dBm
2. DC voltage: 0 V
3. Operating Temperature: -30°C to +85°C
4. Storage Temperature: -40°C to +85°C

B. ELECTRICAL CHARACTERISTICS:

1. Source Impedance (single ended): 50Ω
2. Load Impedance (single ended): 50Ω

Parameters Description	Unit	Min.	Typ.	Max.
Center Frequency (Fc)	MHz	-	881.5	-
Insertion Loss within 869.0 ~ 894.0MHz	dB	-	1.6	2.3
Amplitude Ripple within 869.0 ~ 894.0MHz	dB p-p	-	0.4	1.3
VSWR within 869.0 ~ 894.0MHz	-	-	1.6	2.0
Attenuation:				
DC ~ 824.0MHz	dB	40	51	-
824.0 ~ 849.0MHz	dB	40	46	-
914.0 ~ 970.0MHz	dB	25	35	-
970.0 ~ 1049.0MHz	dB	38	52	-
1049.0 ~ 2000.0MHz	dB	33	43	-
2000.0 ~ 3000.0MHz	dB	25	39	-
3000.0 ~ 6000.0MHz	dB	20	36	-

SAW Filter 881.50MHz
Part No: MP07842

Model: TA1811A
Rev No: 1

C. FREQUENCY CHARACTERISTICS:

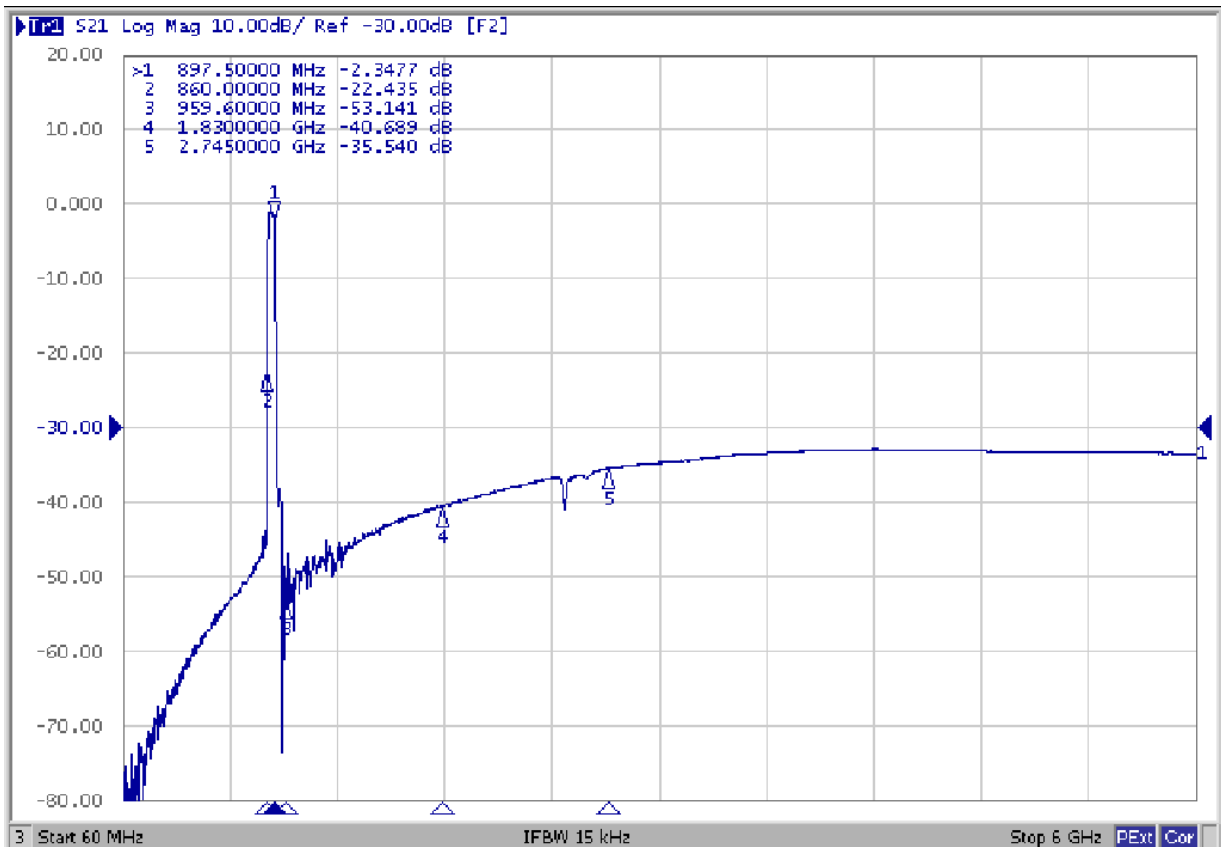
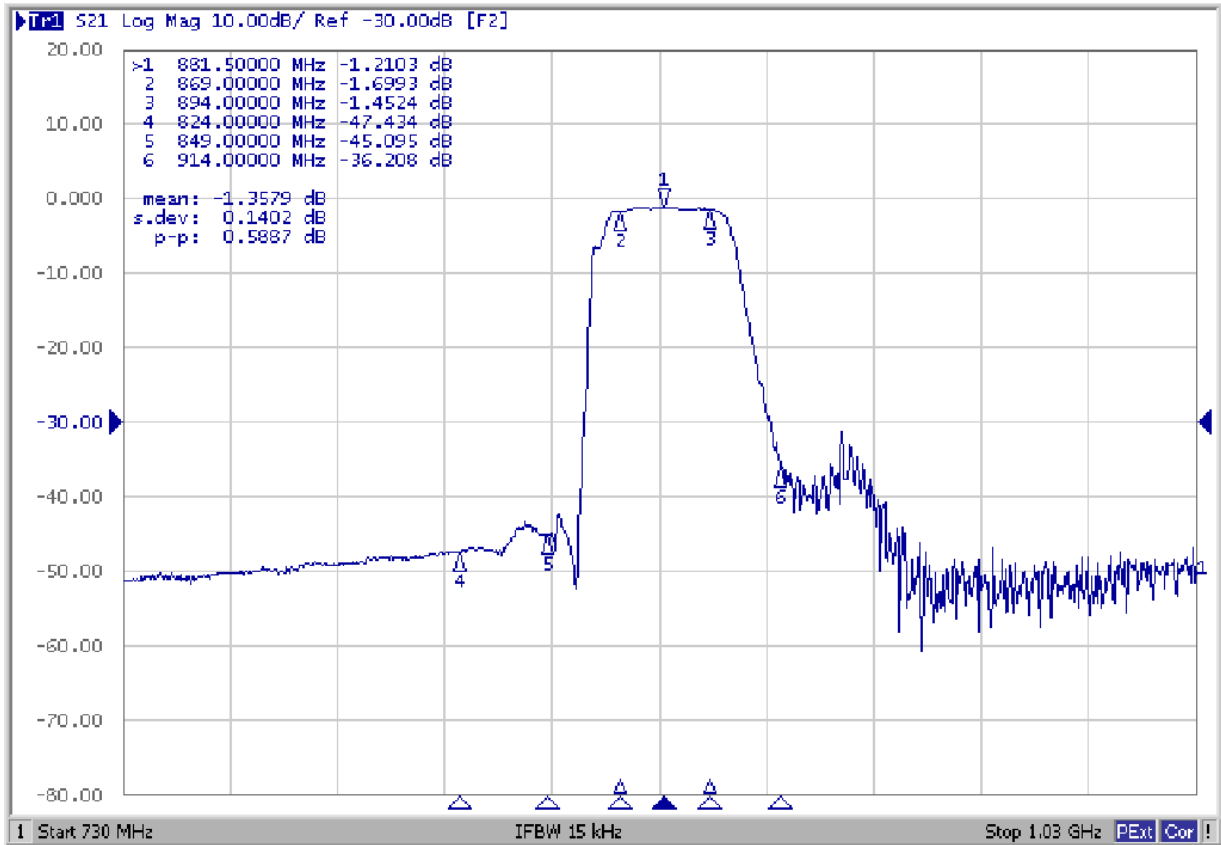

SAW Filter 881.50MHz
Part No: MP07842

Model: TA1811A
Rev No: 1

1. VSWR

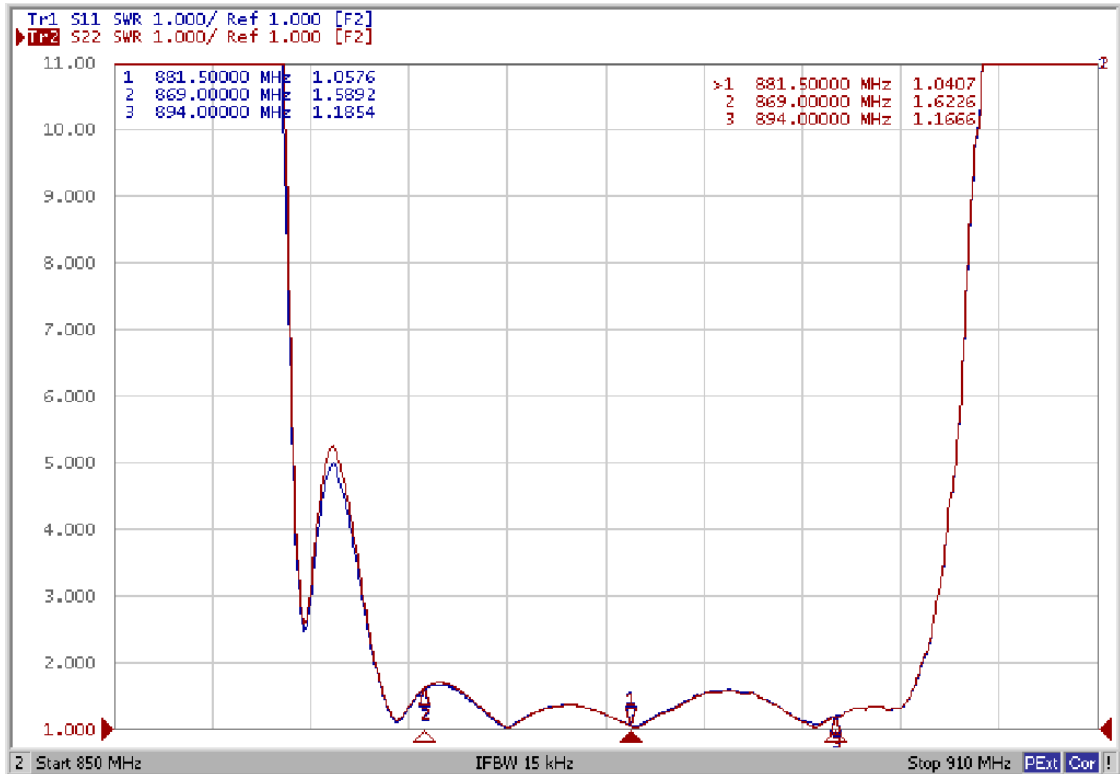

2. Ripple

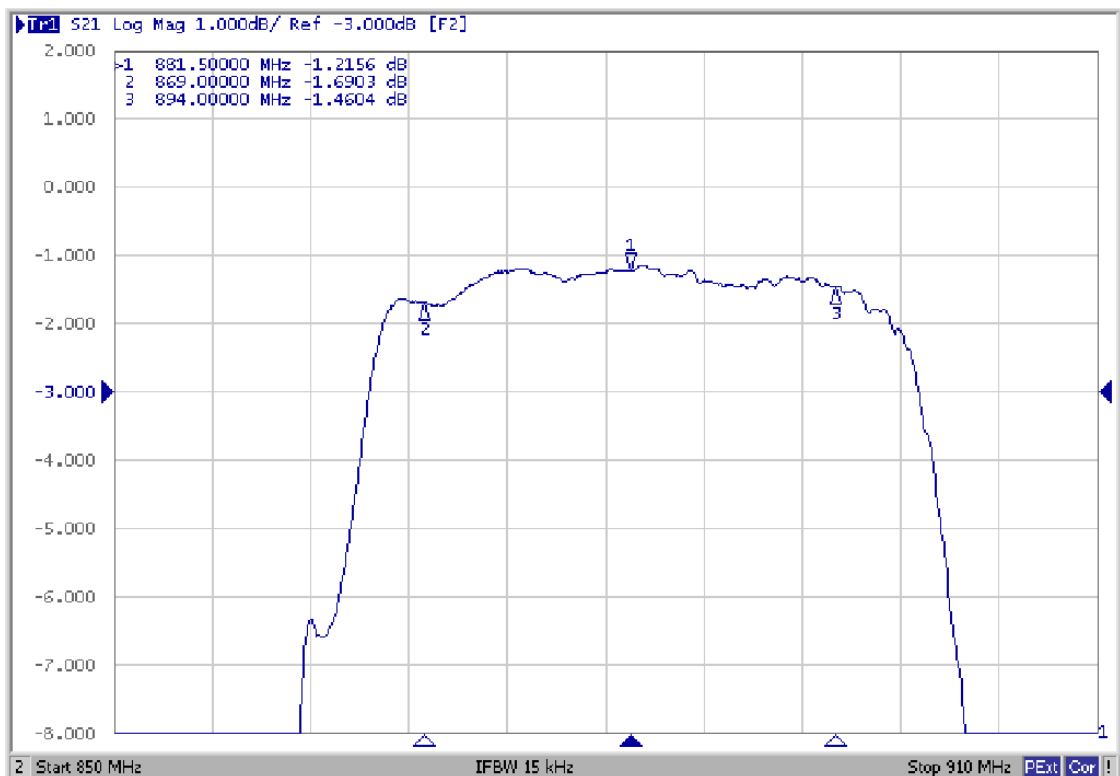

SAW Filter 881.50MHz
Part No: MP07842

Model: TA1811A
Rev No: 1

3. Smith Chart

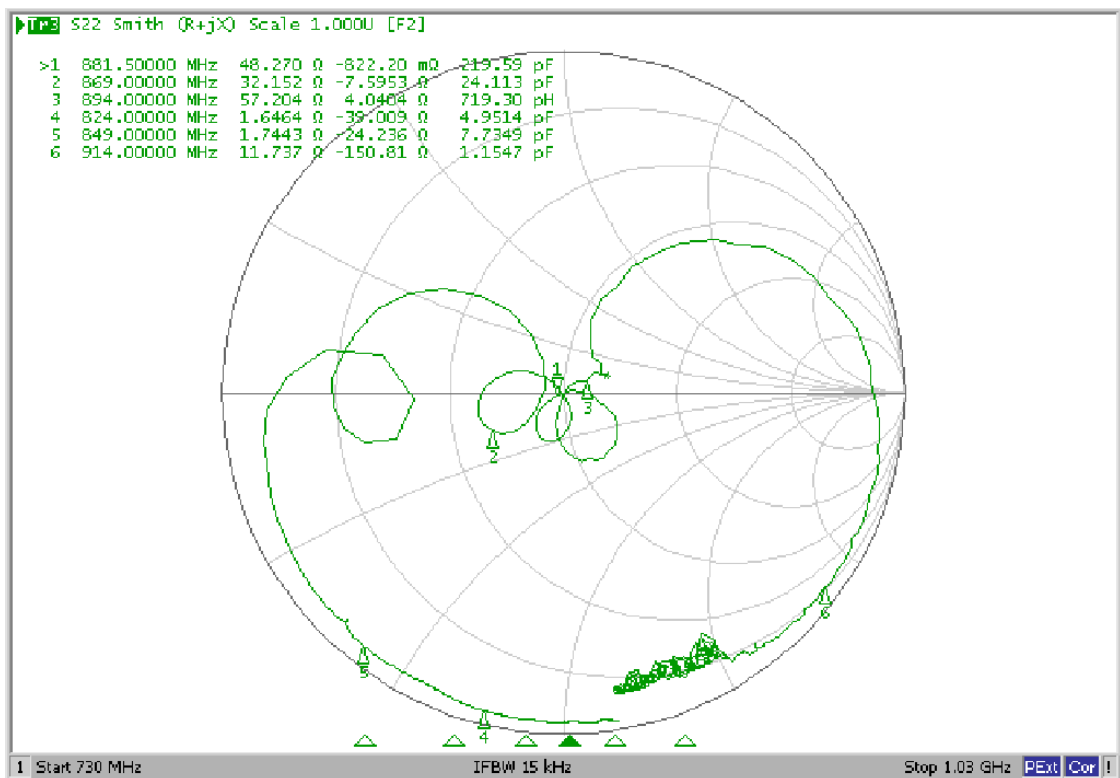
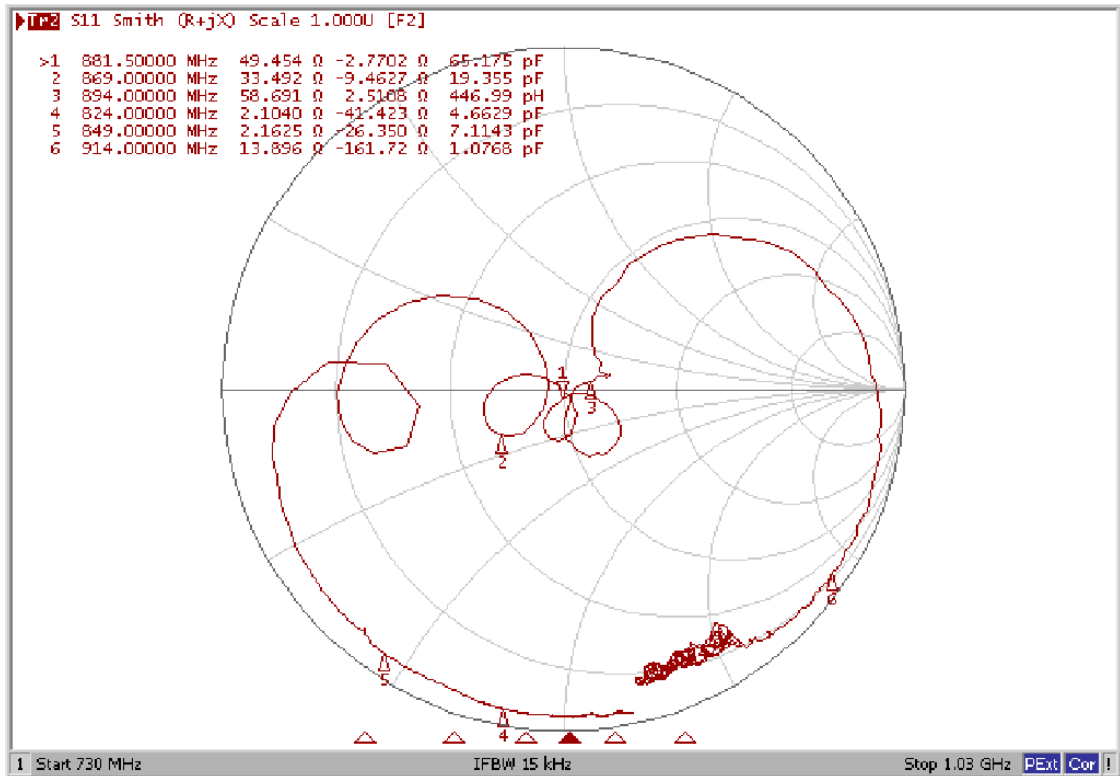

SAW Filter 881.50MHz
Part No: MP07842

Model: TA1811A
Rev No: 1

D. MEASUREMENT CIRCUIT:

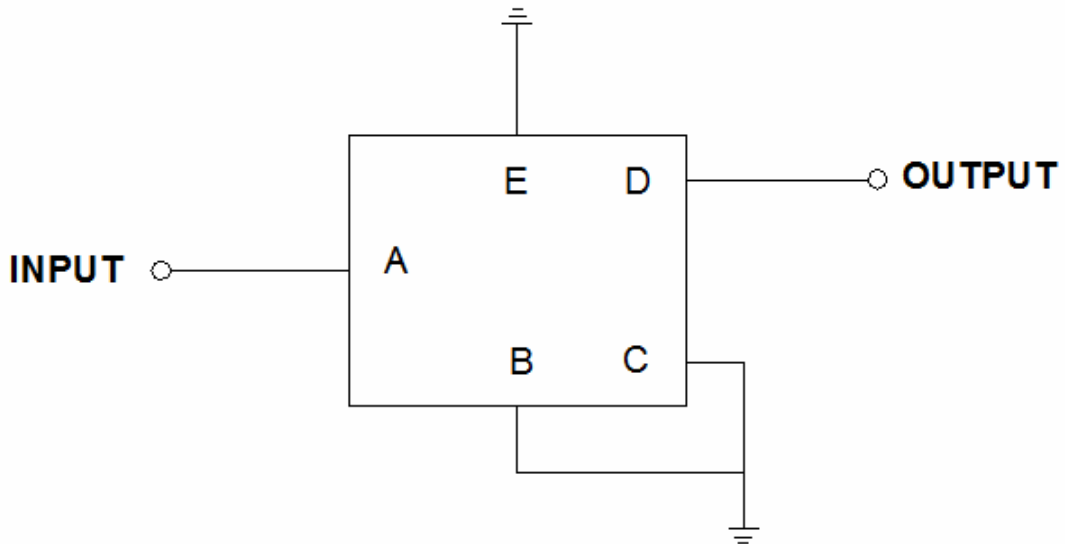

Source Impedance: 50Ω
Load Impedance: 50Ω

E. OUTLINE DRAWING:

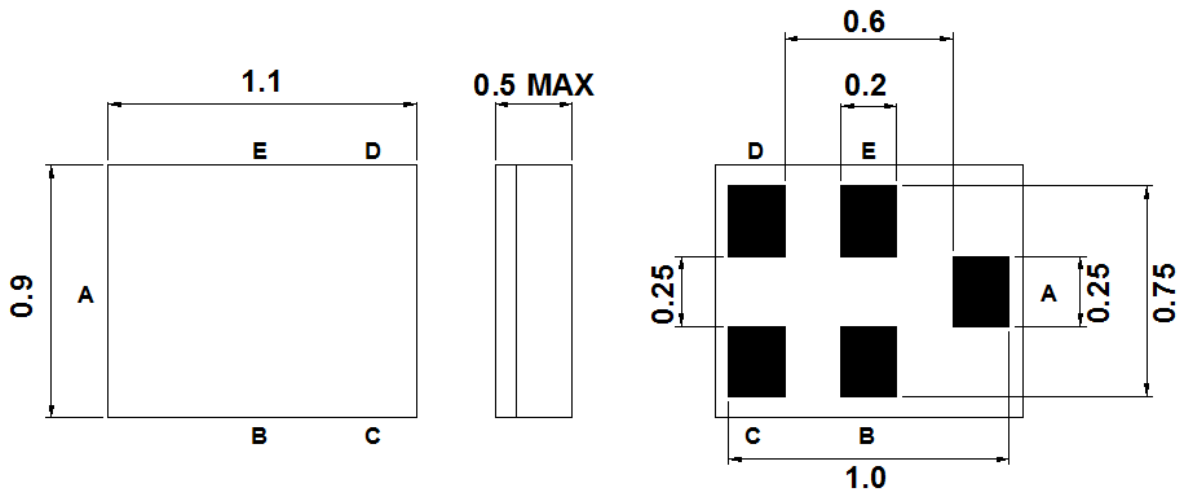

B, C, E: Ground
A: Input
D: Output

SAW Filter 881.50MHz
Part No: MP07842

Model: TA1811A
Rev No: 1

G. RECOMMENDED REFLOW PROFILE:

