

SAW Filter 1586.0MHz
Part No: MP09735

Model: TA1586LL
Rev No: 1

A. MAXIMUM RATING:

1. Input Power Level: 30dBm (*)
2. DC Voltage: 3V
3. Operating Temperature: -20°C to +70°C
4. Storage Temperature: -40°C to +85°C

B. ELECTRICAL CHARACTERISTICS:

Item	Unit	Min.	Typ.	Max.
Center frequency Fc	MHz	-	1586	-
Insertion loss at 1586MHz IL	dB	-	0.9	1.5
Amplitude ripple (1565 ~ 1607MHz)	dB	-	0.9	1.5
VSWR (1565 ~ 1607MHz)		-	1.9	2.3
Attenuation (Reference level from 0dB)				
D.C. ~ 600MHz	dB	12	18	-
600 ~ 1480MHz	dB	10	16	-
1630 ~ 1650MHz	dB	14	31	-
1650 ~ 3000MHz	dB	10	17	-
Source impedance Z _S	Ω	-	50	-
Load impedance Z _L	Ω	-	50	-

(*): Power input period is 10 sec.

C. MEASUREMENT CIRCUIT:

HP Network analyzer

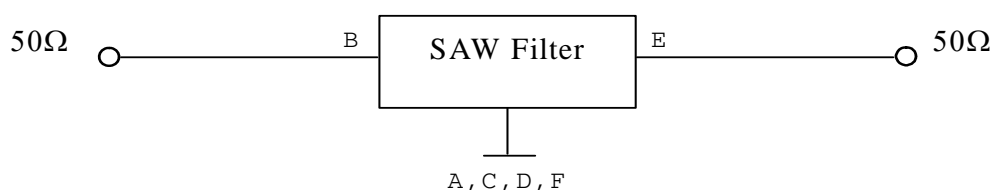

SAW Filter 1586.0MHz
Part No: MP09735

Model: TA1586LL
Rev No: 1

D. OUTLINE DRAWING:

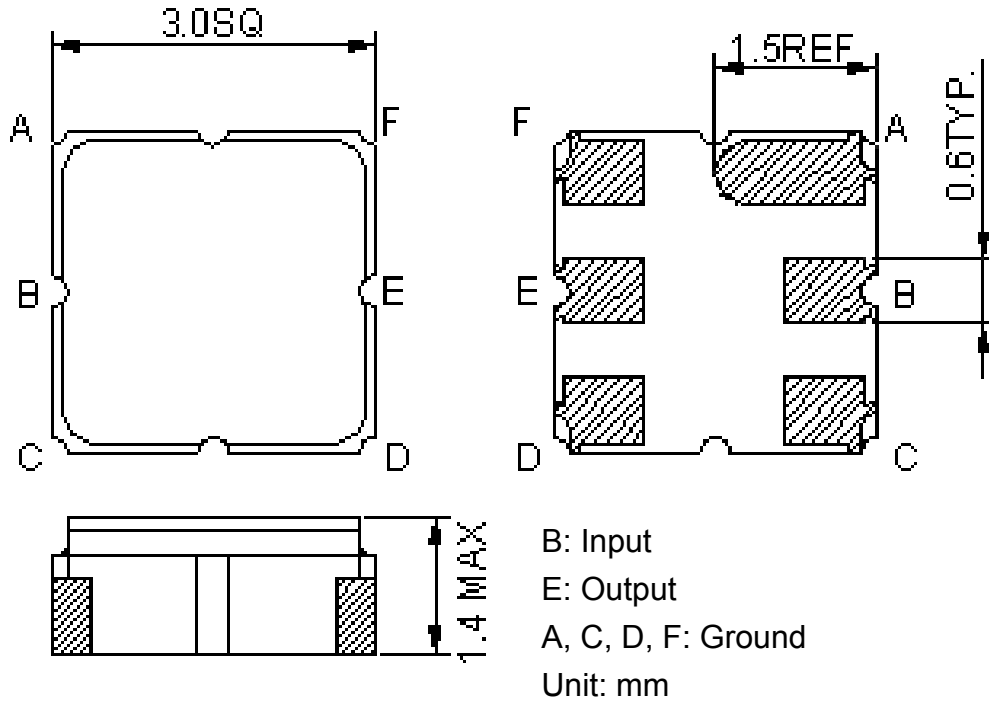

E. PCB FOOTPRINT:

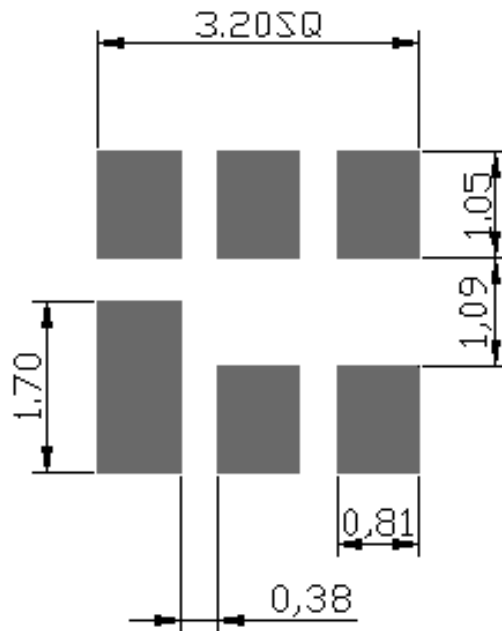

SAW Filter 1586.0MHz
Part No: MP09735

Model: TA1586LL
Rev No: 1

F. FREQUENCY CHARACTERISTICS:

1. Wideband response: (1 ~ 3000MHz)

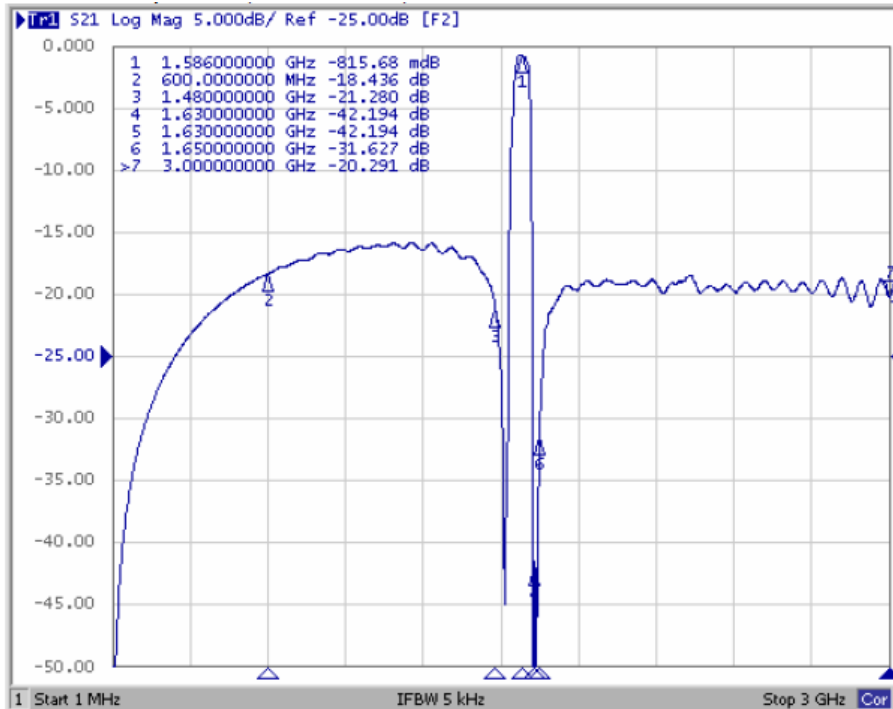

2. Narrowband response: (span200MHz)

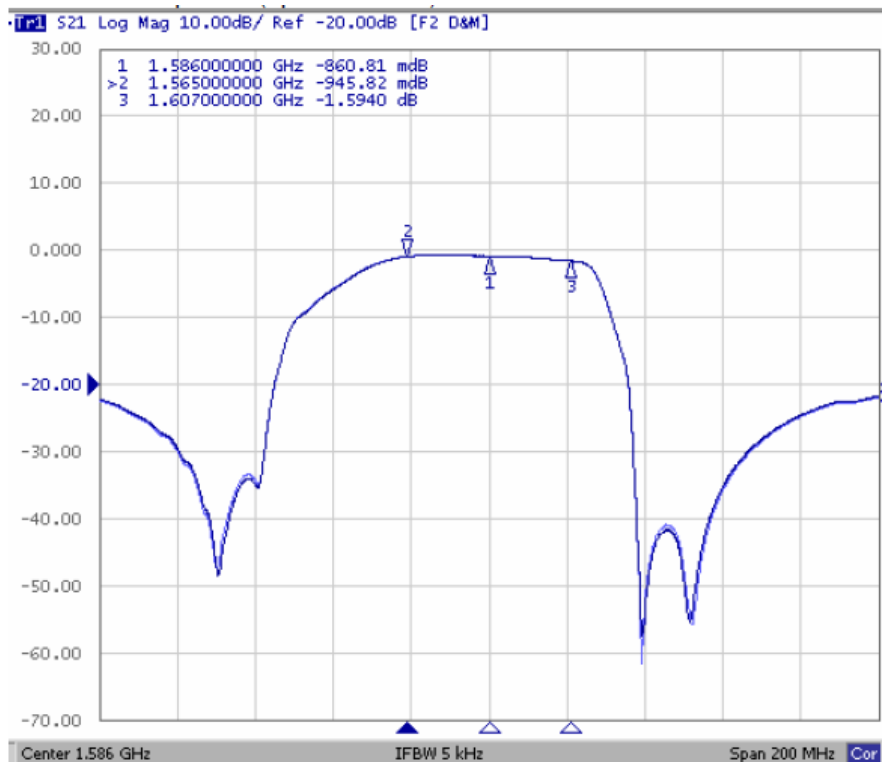

SAW Filter 1586.0MHz
Part No: MP09735

Model: TA1586LL
Rev No: 1

3. VSWR (span 200MHz)

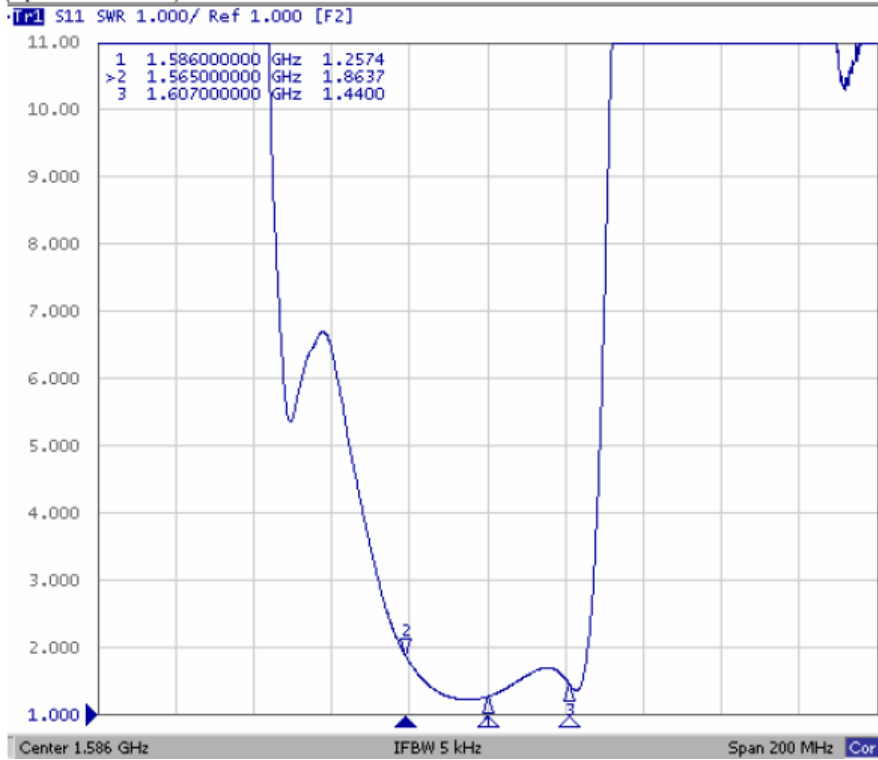

SAW Filter 1586.0MHz
Part No: MP09735

Model: TA1586LL
Rev No: 1

G. PACKING:

1. Reel Dimension

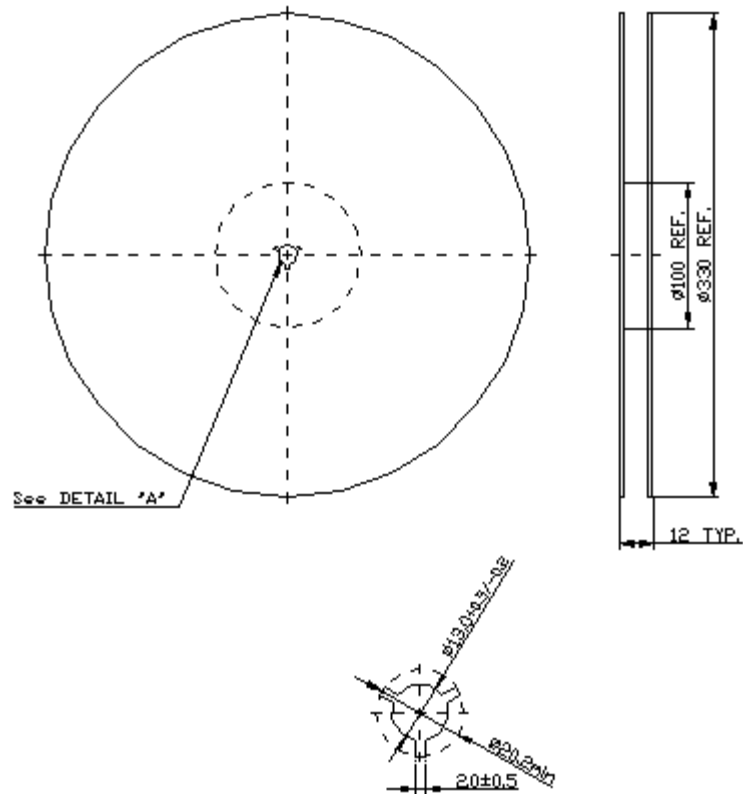

2. Tape Dimension

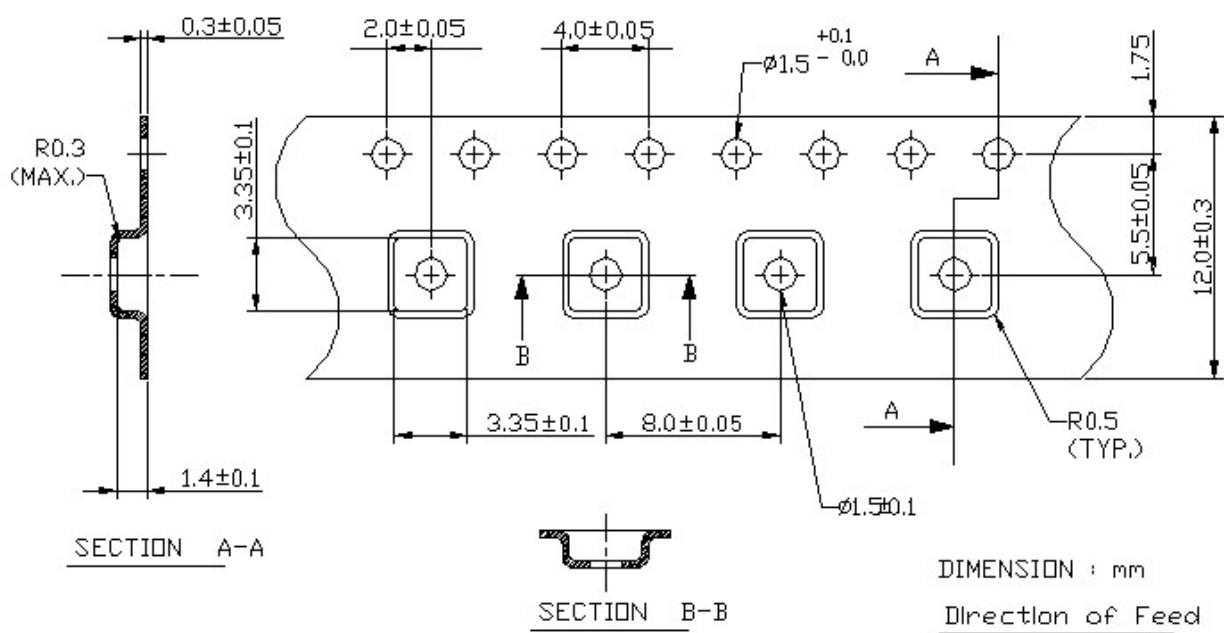

SAW Filter 1586.0MHz
Part No: MP09735

Model: TA1586LL
Rev No: 1

H. RECOMMENDED REFLOW PROFILE:

