

**SAW Filter 440.0MHz**  
**Part No: MP07671**

**Model: TA1808A**  
**Rev No: 1**

**A. MAXIMUM RATING:**

Electrostatic Sensitive Device (ESD)

1. Input Power Level: 10dBm
2. DC Voltage: 5V
3. Operating Temperature: -40°C to +85°C
4. Storage Temperature: -40°C to +85°C

**B. ELECTRICAL CHARACTERISTICS:**

Item	Unit	Min	Typ	Max
Center frequency Fc	MHz	-	440	-
Insertion loss (430 ~ 450MHz) IL	dB	-	2.4	3.51)
Amplitude Ripple (430 ~ 450MHz)	dB	-	0.9	2.32)
Return loss (430~450 MHz)	dB	6	7	-
Attenuation (Reference level from 0dB)				
0.3 ~ 300MHz	dB	50	60	-
300 ~ 380MHz	dB	45	50	-
380 ~ 400MHz	dB	40	50	-
480 ~ 880MHz	dB	40	50	-
880 ~ 915MHz	dB	45	55	-
915 ~ 1200MHz	dB	30	40	-
1200 ~ 1785MHz	dB	25	35	-
Temperature Coefficient of Frequency	ppm/°C	-	-36	-

1. 2.4dB at 25°C; 3.3dB for -30°C to +60°C
2. 1.1dB at 25°C; 2.2dB for -30°C to +60°C

**SAW Filter 440.0MHz**  
**Part No: MP07671**

**Model: TA1808A**  
**Rev No: 1**

**C. MEASUREMENT CIRCUIT:**

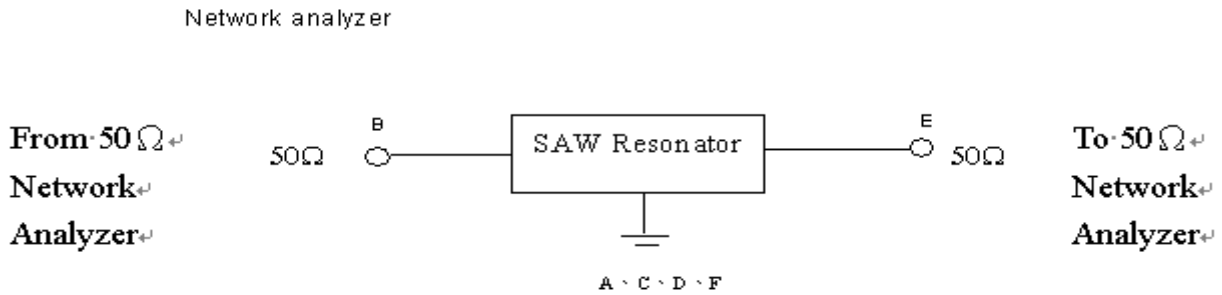

**D. OUTLINE DRAWING:**

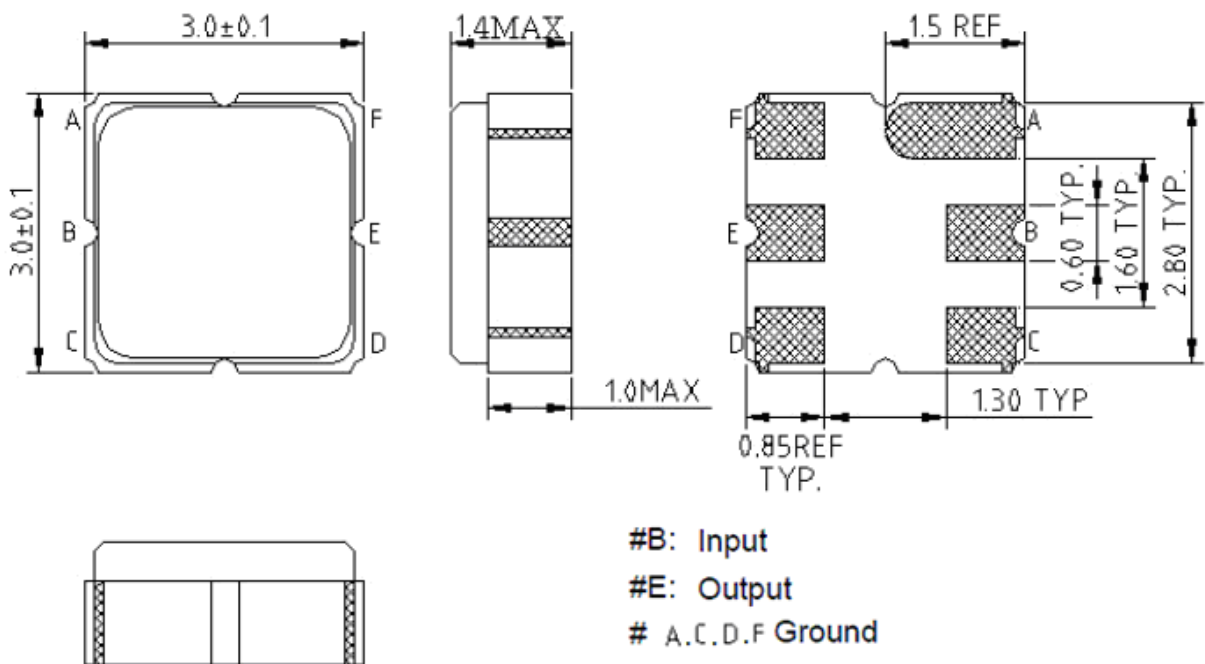

Unit: mm

**SAW Filter 440.0MHz**  
**Part No: MP07671**

**Model: TA1808A**  
**Rev No: 1**

**E. FREQUENCY CHARACTERISTICS:**

1. S21 Measurement: span 200MHz

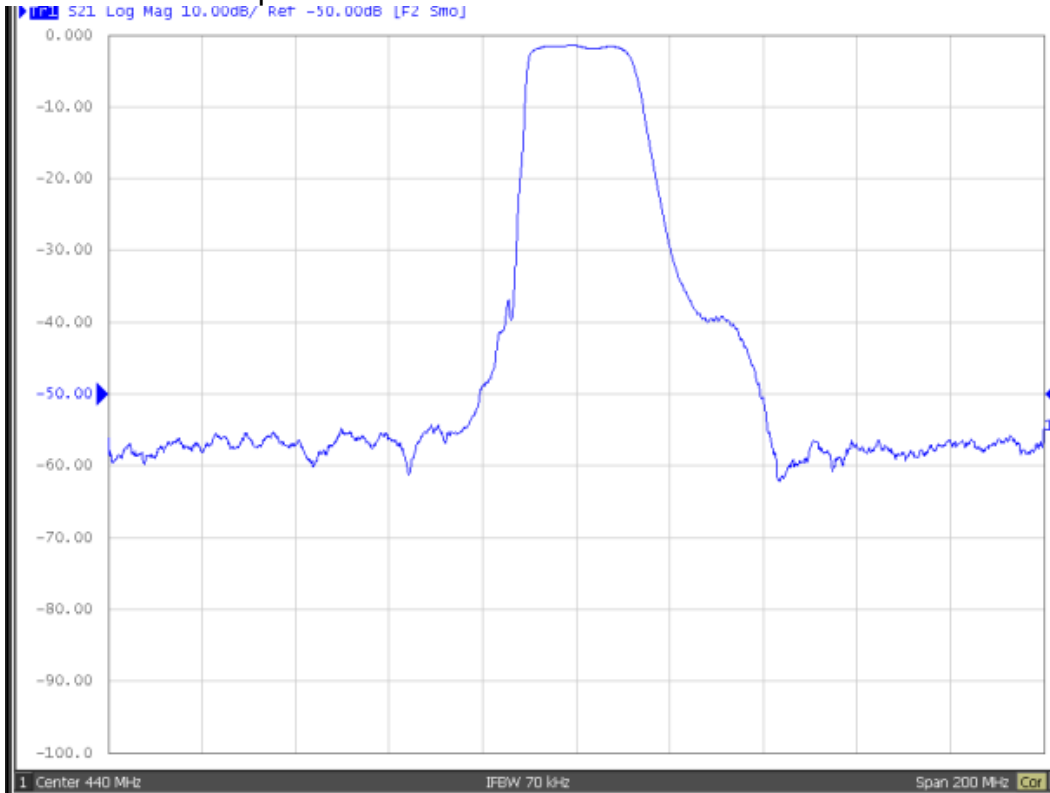

2. S21 Measurement: Span 50MHz

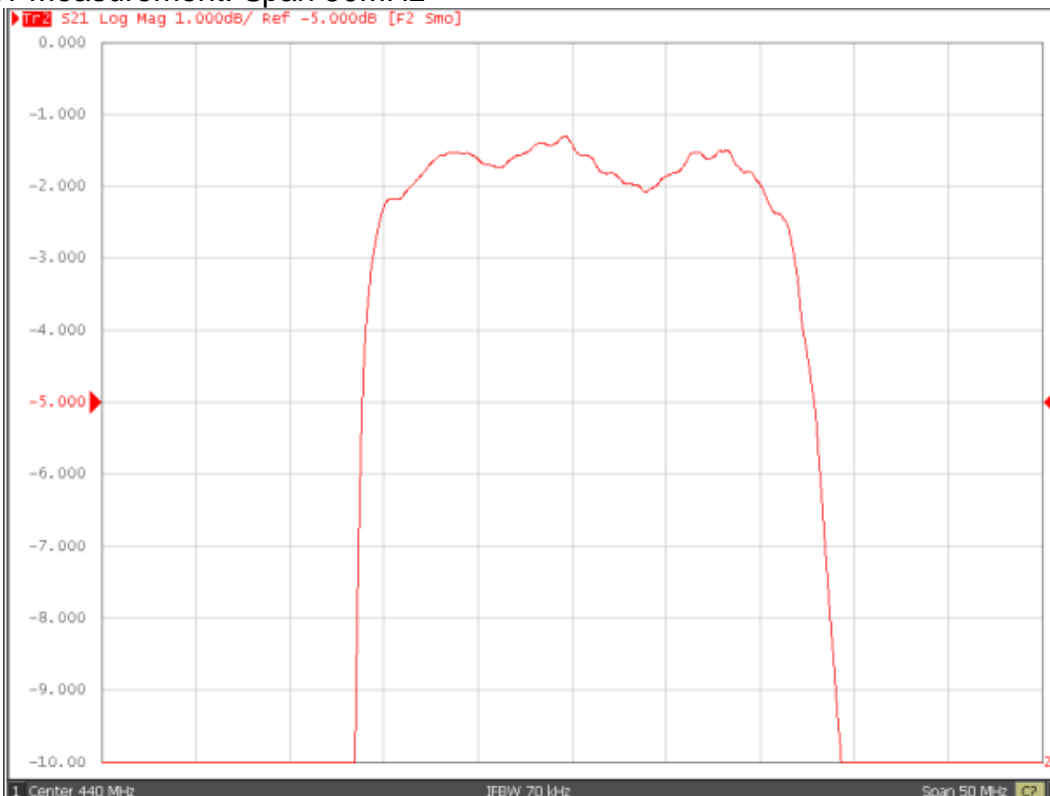

**SAW Filter 440.0MHz**  
**Part No: MP07671**

**Model: TA1808A**  
**Rev No: 1**

### 3. S21 Measurement: Span 3GHz

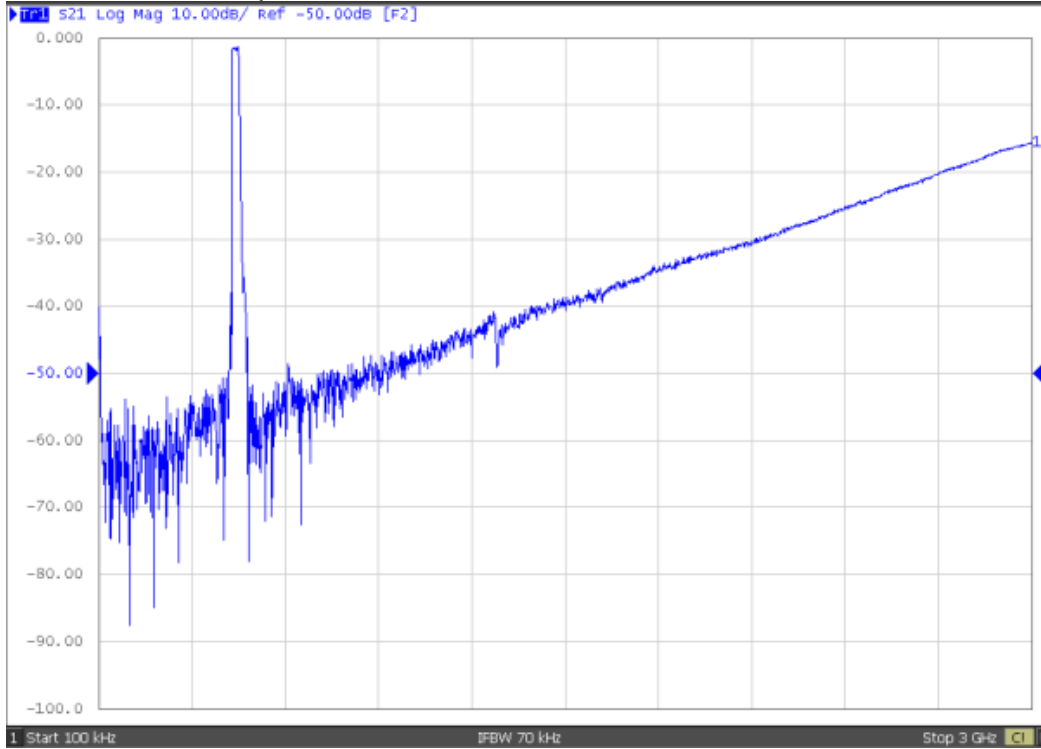

### 4. S11/S22 Measurement:

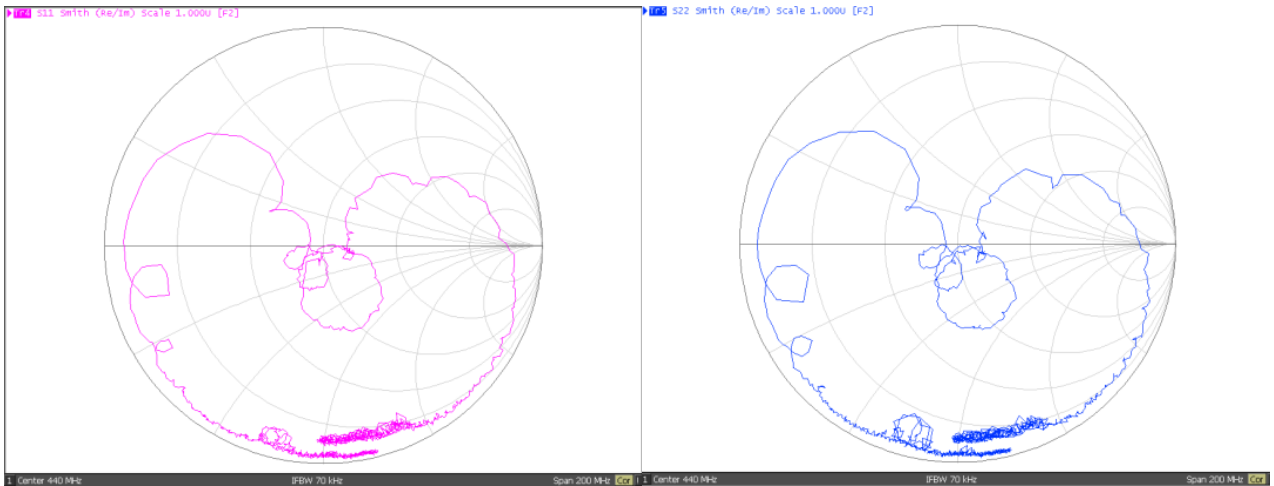

**SAW Filter 440.0MHz**  
**Part No: MP07671**

**Model: TA1808A**  
**Rev No: 1**

**F. PACKING:**

1. Reel Dimension

(Please refer to FR-75D10 for packing quantity)

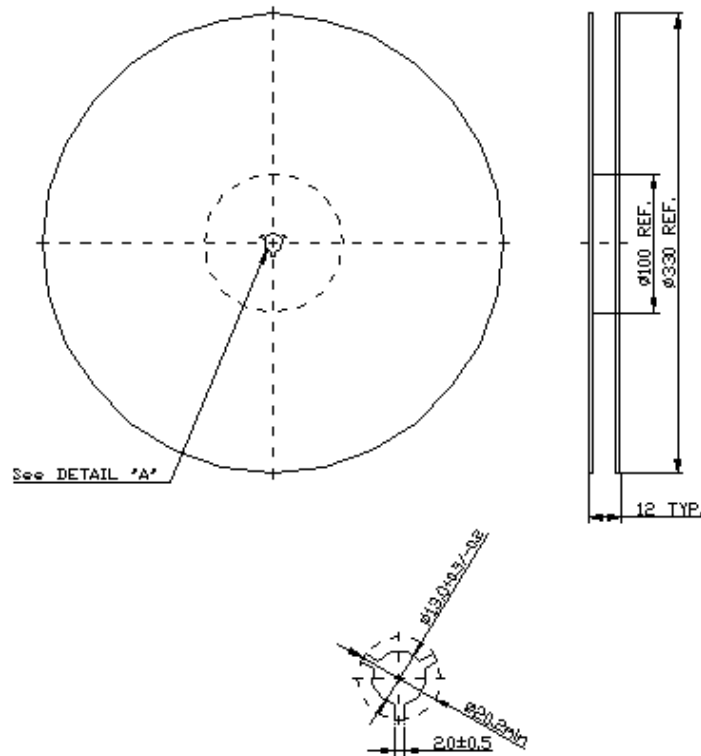

2. Tape Dimension

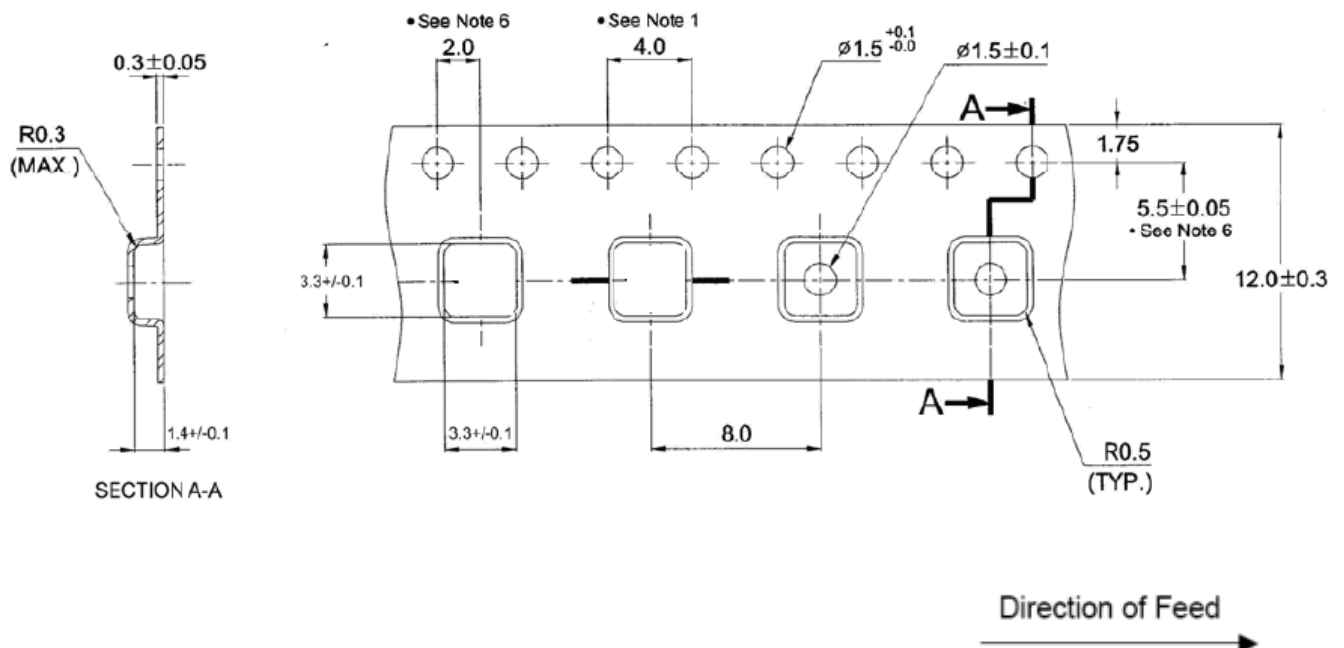

**SAW Filter 440.0MHz**  
**Part No: MP07671**

**Model: TA1808A**  
**Rev No: 1**

**G. RECOMMENDED REFLOW PROFILE:**

1. Preheating shall be fixed at 150 ~ 180°C for 60 ~ 90 seconds.
2. Ascending time to preheating temperature 150°C shall be 30 seconds min.
3. Heating shall be fixed at 220°C for 50 ~ 80 seconds and at 260°C +0/-5°C peak (20 ~ 40 sec).
4. Time: 2 times.

