

SAW Filter 1870MHz
Part No: MP01669

Model: TA0604A
Rev No: 1

A. MAXIMUM RATING:

1. Input Power Level: 10dBm
2. DC Voltage: 5V
3. Operating Temperature: -30°C to +85°C
4. Storage Temperature: -40°C to +85°C

B. ELECTRICAL CHARACTERISTICS:

Item	Unit	Min.	Typ.	Max.	Note
Center Frequency Fc	MHz	-	1870	-	-
Insertion Loss (1840 ~ 1900MHz) IL	dB	-	2.6	4	-
Amplitude Ripple (1840 ~ 1900MHz)	dB	-	1.2	2.5	-
I/O Return Loss (1840 ~ 1900MHz)	dB	7.4	11	-	-
Relative Attenuation (relative to 0dB)					
DC ~ 1660MHz	dB	20	31	-	-
1660 ~ 1721MHz	dB	30	36	-	-
1721 ~ 1790MHz	dB	20	42	-	-
1920 ~ 1990MHz	dB	7	18	-	-
2000 ~ 2040MHz	dB	25	39	-	-
2040 ~ 2480MHz	dB	31	38	-	-
3700 ~ 3820MHz	dB	25	32	-	-

C. MEASUREMENT CIRCUIT:

HP Network analyzer

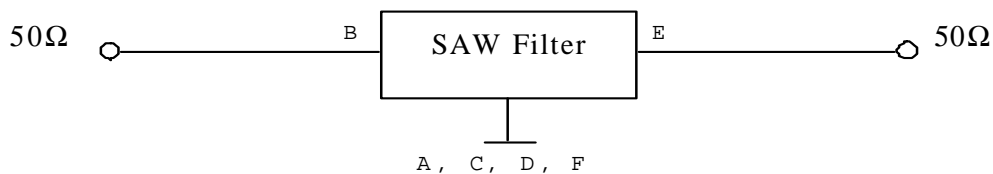

SAW Filter 1870MHz
Part No: MP01669

Model: TA0604A
Rev No: 1

D. OUTLINE DRAWING:

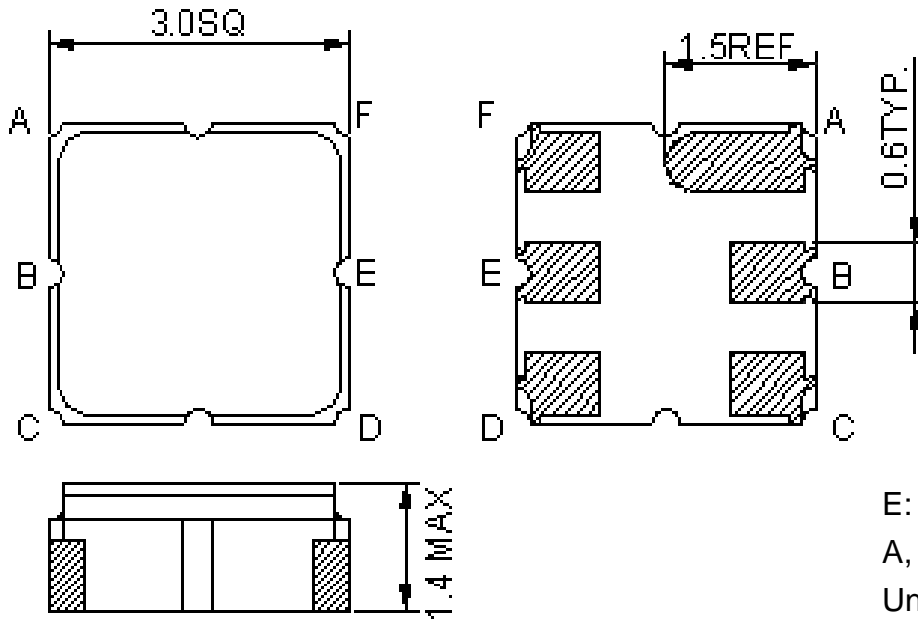

E. PCB FOOTPRINT:

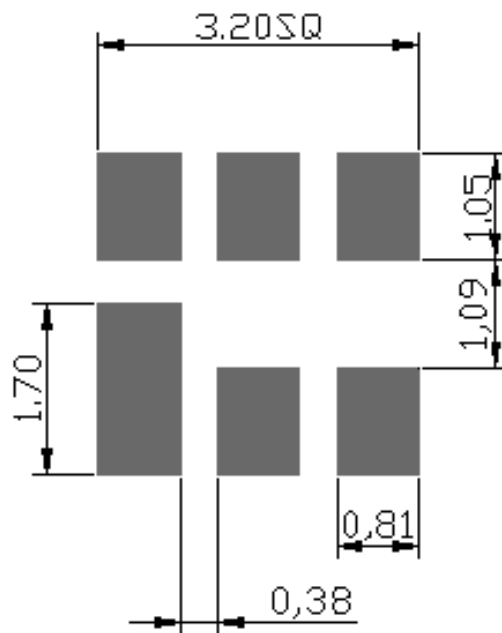

SAW Filter 1870MHz
Part No: MP01669

Model: TA0604A
Rev No: 1

F. FREQUENCY CHARACTERISTICS:

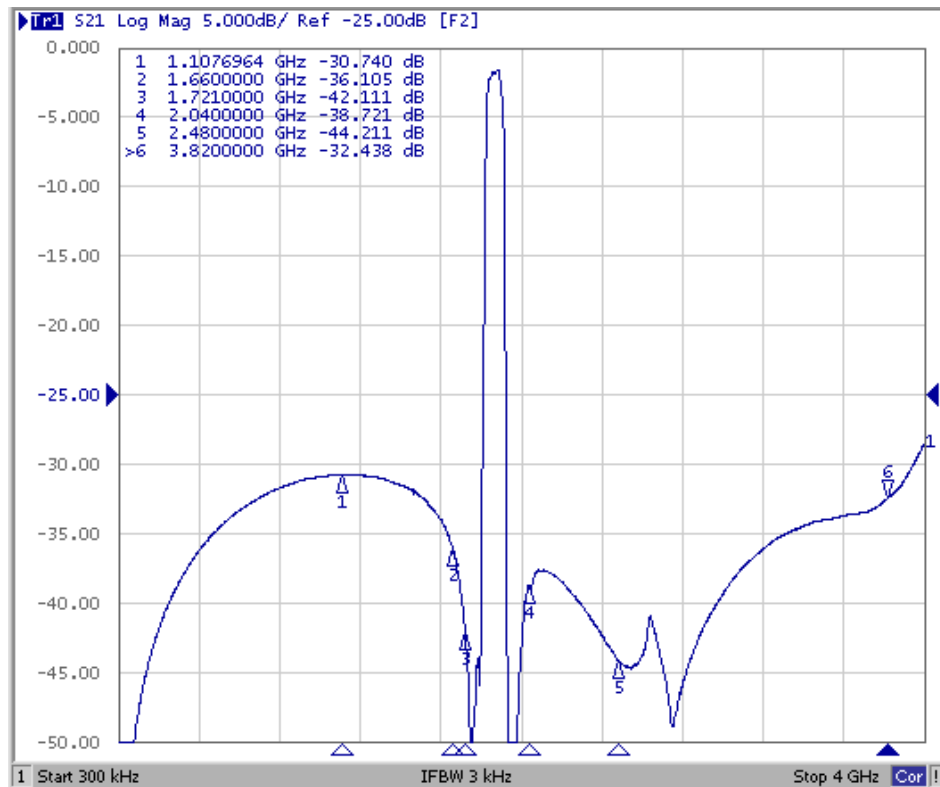
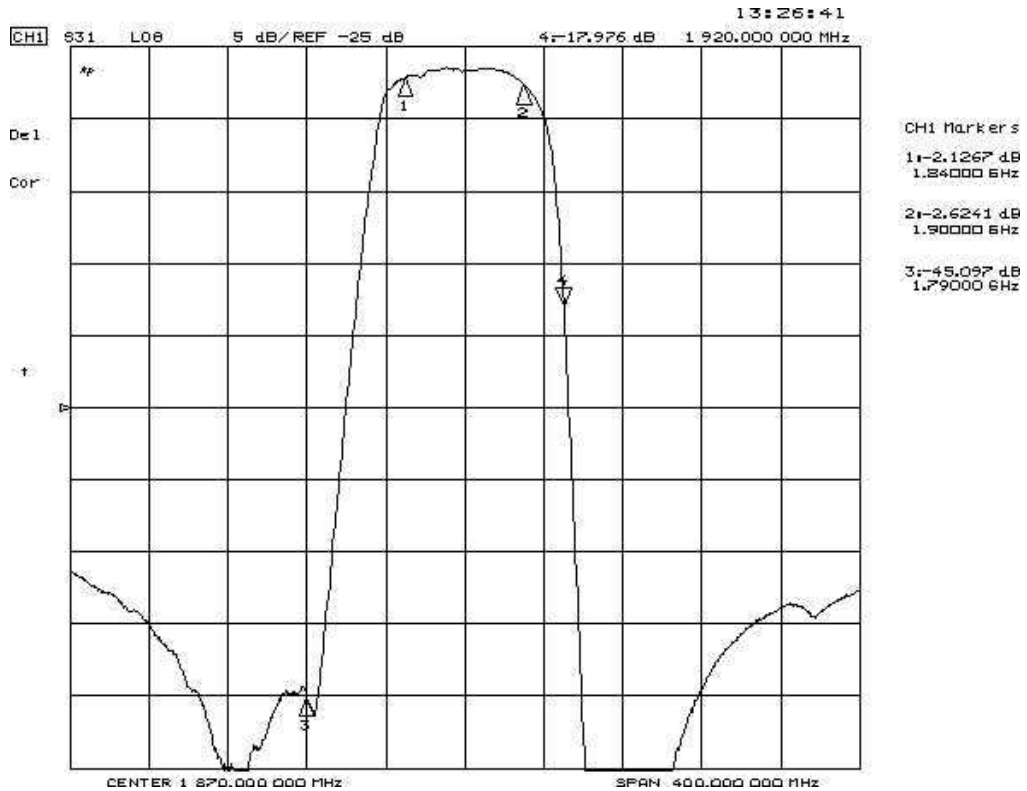

SAW Filter 1870MHz
Part No: MP01669

Model: TA0604A
Rev No: 1

Reflection Functions

S11

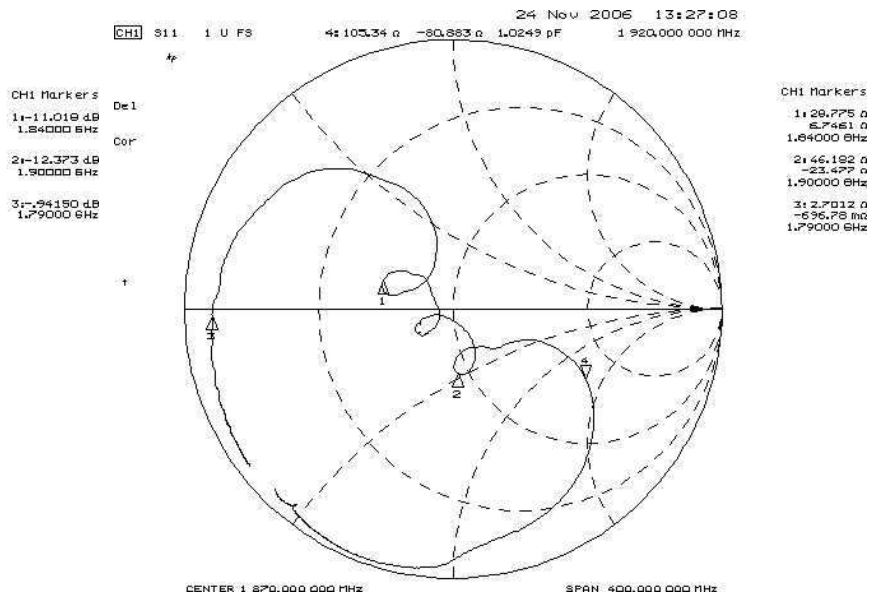

S22

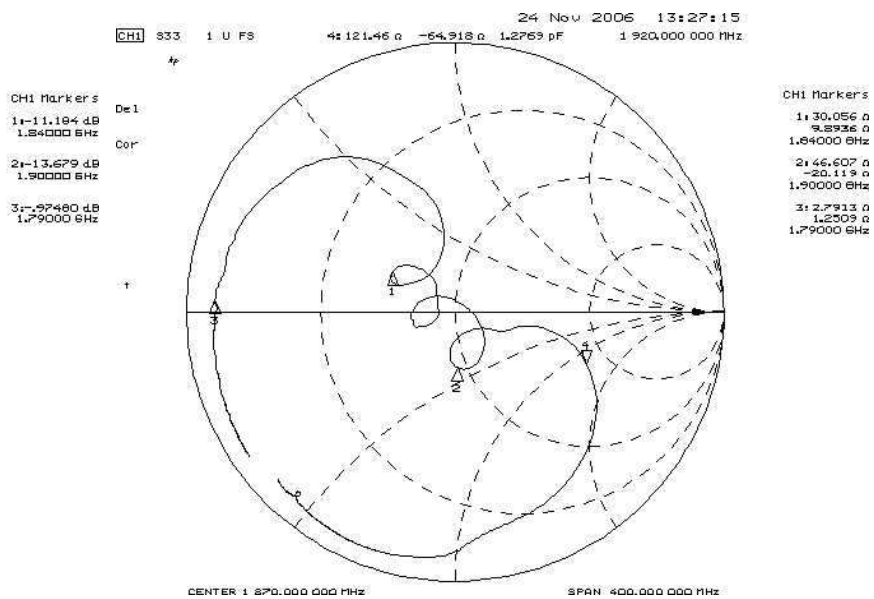
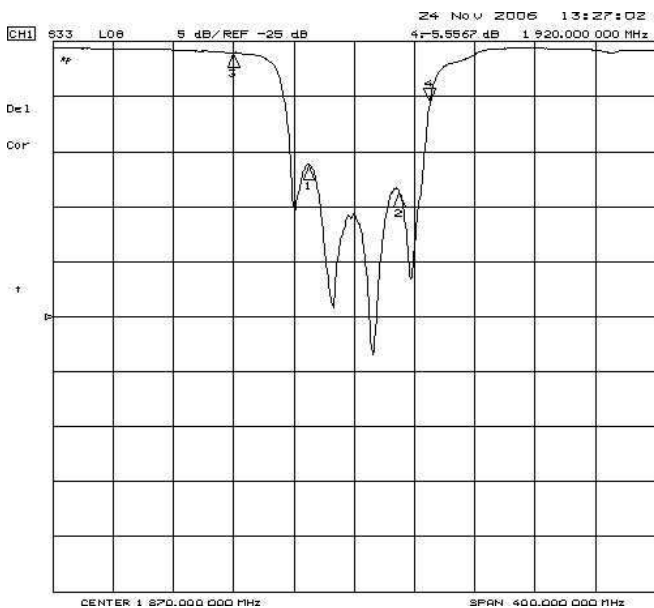

SAW Filter 1870MHz
Part No: MP01669

Model: TA0604A
Rev No: 1

H. RECOMMENDED REFLOW PROFILE:

